

Technical Specifications (In-Cash Procurement)

Nuclear safety qualification test of diagnostic windows

This specification outlines technical requirements for nuclear safety qualification testing of Primary Vacuum Windows Assemblies (55.NW), focusing on qualifying the sealing components that serve as both a safety confinement barrier and vacuum boundary.

Service

Table of Contents

1	PREAMBLE	3
2	PURPOSE	3
3	ACRONYMS & DEFINITIONS	3
3.1	Acronyms	3
3.2	Definitions	4
4	APPLICABLE AND REFERENCE DOCUMENTS & CODES AND STANDARDS	4
4.1	Applicable documents	4
4.2	Reference documents	4
4.3	Applicable Codes and Standards	4
5	SCOPE OF WORK	5
5.1	Brief design description of PVM	5
5.2	Design of window prototypes for qualification testing	7
5.3	Qualification program	7
5.4	Free-issue items	8
6	TECHNICAL REQUIREMENTS	8
6.1	Chemical aging test	8
6.2	Thermal cycling test	10
6.3	Vibration tests	11
6.3.1	Vibration tests for seismic events	12
6.3.2	Vibration tests for VDE events at low frequency (<100Hz)	12
6.3.3	Sinusoidal vibration tests for VDE events at high frequency (100-2000 Hz)	13
6.4	Thermal test for fire load	13
6.5	Pressure test for internal explosion	14
6.6	Impact test for load drop	16
6.7	Free drop test for vibration at high frequencies during VDE	17
6.8	Actions to be implemented in case of thermal cycling test failure	18
7	DELIVERABLES AND SCHEDULE MILESTONES	19
8	QUALITY ASSURANCE REQUIREMENTS	20
8.1	Qualification Test Plan	20
8.2	Audit and other Inspections	22
8.3	Deviation Request (DR)	22
8.4	Non-conformity	22

Service

9 SAFETY REQUIREMENTS22

10 CONTRACT MANAGEMENT24

**APPENDIX I - FRS DATA TO BE CONSIDERED FOR THE WINDOW
QUALIFICATION25**

APPENDIX II – QUALIFICATION TEST PLAN TEMPLATE.....29

**APPENDIX III – DEFINED REQUIREMENTS APPLICABLE TO THIS
CONTRACT 30**

Service

1 Preamble

This Technical Specification is to be read in combination with the General Management Specification for Service and Supply (GM3S) [AD1] that constitutes a full part of the technical requirements.

In case of conflict, the content of the Technical Specification supersedes the content of [AD1].

2 Purpose

This specification outlines technical requirements for nuclear safety qualification testing of Primary Vacuum Windows Assemblies (55.NW), focusing on qualifying the sealing components that serve as both a safety confinement barrier and vacuum boundary.

3 Acronyms & Definitions

3.1 Acronyms

The following acronyms are the main one relevant to this document.

Abbreviation	Description
CRO	Contract Responsible Officer
CV	Clear Viewsize
DR	Deviation Request
FRS	Frequency Response Spectrum
FSi	Fused Silica
GM3S	General Management Specification for Service and Supply
IO	ITER Organization
IVH	ITER Vacuum Handbook
NCR	Non-Conformity Report
PIA	Protection Important Activities
PIC	Protection Important Components
PRO	Procurement Responsible Officer
PSD	Power Spectral Density
PVM	Primary Vacuum Window
QP	Quality Plan
QTP	Qualification Test Plan
SIC	Safety Important Components
SVS	Service Vacuum System
ZPA	Zero Period Acceleration
55.NW	Primary Vacuum Windows Assemblies

Service

3.2 Definitions

Contractor: shall mean an economic operator who have signed the Contract in which this document is referenced.

4 Applicable and reference documents & Codes and standards

4.1 Applicable documents

This list contains mandatory documents that the contract shall be compliant with.

[AD1] [General Management Specification for Service and Supply \(82MXQK v1.4\)](#)

[AD2] [Provisions for Implementation of the Generic Safety Requirements by the External Actors/Interveners \(SBSTBM v2.2\)](#)

[AD3] [Propagation of the Defined Requirements for Protection Important Components Through the Chain of External Interveners \(BG2GYB v3.3\)](#)

[AD4] [ITER Policy on Safety, Security and Environment Protection Management \(43UJN7 v3.1\)](#)

[AD5] [Quality Requirements for IO Performers \(22MFG4 v6.3\)](#)

[AD6] [Procedure for Management of Nonconformities \(22F53X v9.1\)](#)

4.2 Reference documents

This list contains documents for information:

[RD1] [55.NW - Qualification plan for compression seal windows \(EG9TGC v1.2\)](#)

[RD2] [Appendix 12 Leak Testing \(2EYZ5F v1.4\)](#)

[RD3] [55.NW- System load specification for compression seal windows \(E58ZEJ v1.2\)](#)

[RD4] [Cat.1- chit#19 & Cat.2- chit#24-Preparatory-work-Assessment-of-safety-leak-rate-on-windows \(2SBA9C v1.3\)](#)

[RD5] [Tokamak Seismic Analysis - PIM 432 - Design FRS Input \(8FZSG9 v2.0\)](#)

4.3 Applicable Codes and Standards

This is the responsibility of the Contractor to procure the relevant Codes and Standards applicable to that scope of work.

[RQ-0001] The following Standards shall be referred to in this specification:

- IEC 60068-2-6 - Environmental testing, Test Fc: Vibration (sinusoidal)
- IEC 60068-2-64 - Environmental testing, Test Fh: Vibration, broadband random and guidance
- IEC 60068-2-47 - Mounting of specimens for vibration, impact and similar dynamic tests
- IEC 60068-2-57 - Vibration, time-history and sine-beat method (for time-history control)
- IEC 60068-2-75 - Environmental testing - Test Eh: Hammer tests

[RQ-0002] All materials and testing standards mentioned in this document shall be considered in their last revision at the time of the sign of the contract.

[RQ-0003] Other equivalent national or international standards and codes may be acceptable with prior written IO approval, provided all criteria are satisfied.

Service

5 Scope of Work

This section defines the specific scope of work, in addition to the contract execution requirement as defined in [AD1].

The work scope is to carry out tests required to qualify the sealing components of the primary vacuum windows (PVW). The qualification will include the following tests:

- Chemical aging
- Thermal cycling
- Vibration testing
- Thermal testing for fire load
- Pressure testing for internal explosion
- Impact testing for load drop
- Free drop testing for vibration at high frequencies
- Helium leak testing

IO will provide the window prototypes necessary for the qualification testing.

5.1 Brief design description of PVM

The intrinsic function of the PVM is to transmit optic signal or power to diagnose a plasma or machine conditions.

The PVW forms part of the first nuclear safety confinement barrier in ITER. Their integrity is consequently of prime importance in confining the radioactive products inside the vacuum vessel. Therefore, window assemblies are classified as Safety Important Component Class 1 (SIC-1). The primary confinement boundary shall be fully ensured during all the normal and accidental conditions.

The PVM also provides the primary vacuum boundary which is required to generate a plasma in the machine. The vacuum class is VQC-1.

The PVS is composed of two main components: mating flange and window assembly. The mating flange is welded to the machine as an intermediate component to install the window assembly to the machine.

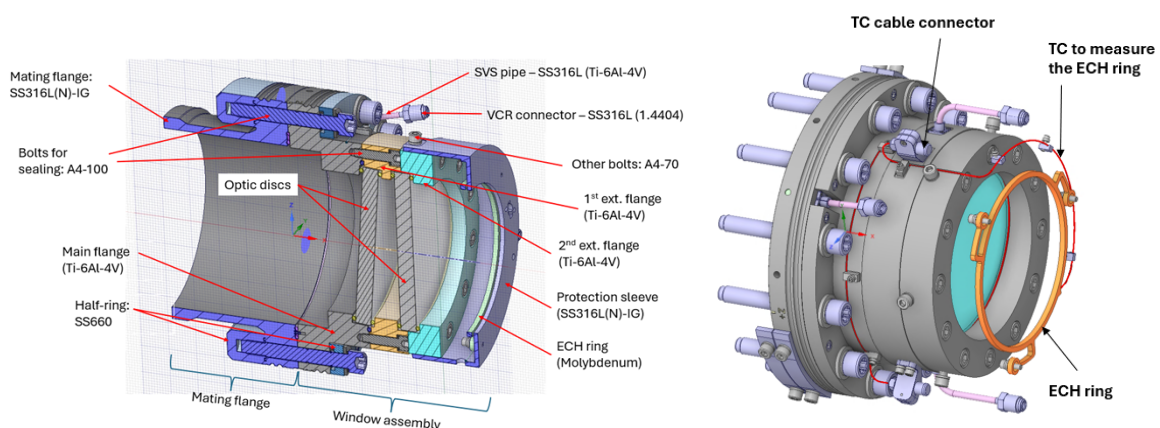

Figure 1 One representative primary vacuum window design

The window assembly consists of the following main parts (see Figure 1 and Figure 2):

- Optic disc(s) made of Fused Silica, Quartz, Sapphire, Zinc Selenide and CVD diamond, depending on the window design variation
- Main flange to be bolted with the mating flange
- Extension flange to be bolted with main flange

Service

- Half rings to press double Helicoflex seal more uniformly
- Double Helicoflex seal (HND229, Technetics product) to provide leak tightness between the mating flange and the main flange
- Single Helicoflex seal Metal gaskets (HNRV200, Technetics product) to provide leak tightness between the flange and the optic disc
- ECH ring made of Molybdenum which are coated with ceramic (Al₂O₃/TiO₂ fixture) on the disc-facing surface
- Thermocouple cable and connector
- Protection sleeve
- SVS pipes and VCR connectors to monitor pressure of the vacuum interspace volume

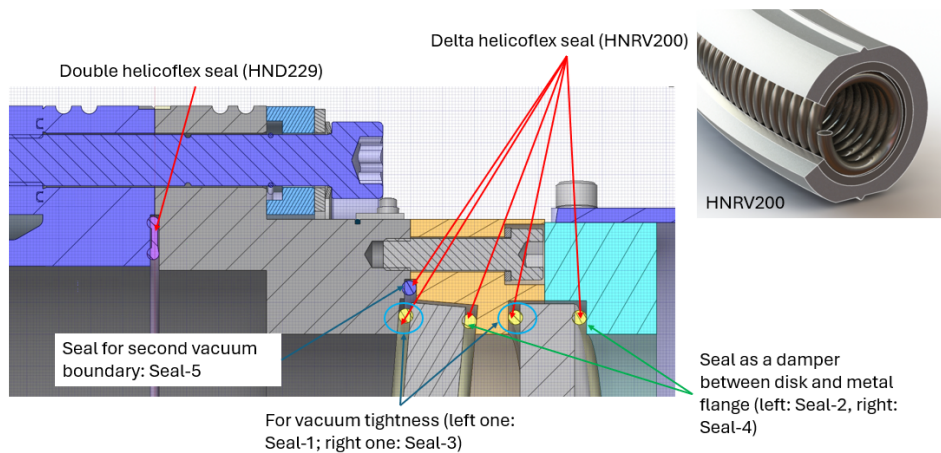

Figure 2 Vacuum sealing of the primary vacuum window

The vacuum-side seal (Seal-2 and Seal-4 in Figure 2) on the optic disk ensures leak tightness, while the seal on the opposite side acts as a damper to stop the brittle disk from making direct contact with the flange. Seal-5 establishes a secondary vacuum boundary by creating a vacuum interspace together with Seal-2, Seal-4, both disks, and the 1st extension flange; this is depicted in Figure 3. Additionally, a small groove has been incorporated into the 2nd extension flange to link the interspace formed by the three seals with the space between the two disks.

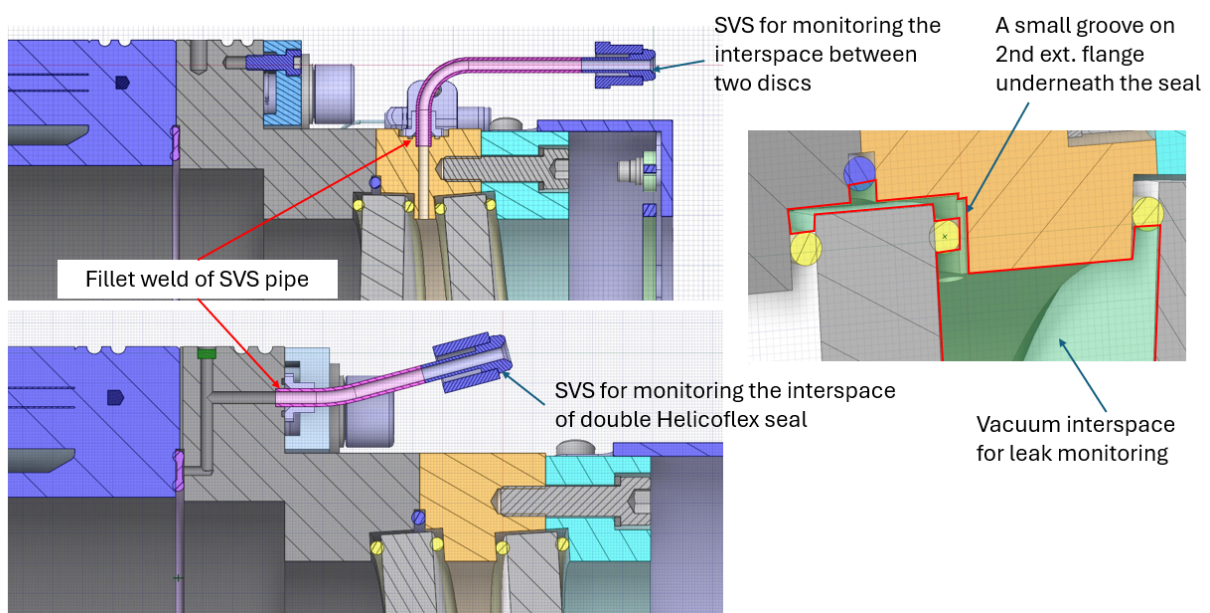

Figure 3 Vacuum interspace volumes for leak monitoring and SVS pipes

Service

Another vacuum interspace is located within the double Helicoflex seal positioned between the mating flange and the main flange. Both of these vacuum interspaces are connected to the ITER service vacuum system (SVS) for leak monitoring purposes, with the SVS pipe welded to the window flange as illustrated in Figure 3.

5.2 Design of window prototypes for qualification testing

The window prototypes will serve as test samples for qualification to justify the nuclear safety function of the windows against normal and abnormal conditions.

The window prototype design is simplified from the original window design described in Section 5.1 to suit qualification needs.

Two distinct window types are selected for qualification testing: CV160 Fused Silica and CV130 Quartz windows. The selection rationale is detailed in [RD1].

Each type must be tested in two configurations, as depicted Figure 4. The testing will begin with five windows in Configuration A, after which certain tests will be conducted on three windows updated to Configuration B from the initial Configuration A group.

The Configuration A window comprises a single disk sealed with Helicoflex seals (HNRV200). The metal part is fabricated from Ti grade 5 (Ti6Al4V). An SVS pipe is attached to the vacuum interspace formed by three seals specifically for He leak testing.

The Configuration B window is updated from the Configuration A window by assembling additional parts. These include a support flange, air-side flange, metal seal (O-flex), bolts, and washers, collectively referred to as “Configuration B parts”. O-flex seal (<https://technetics.com/products/o-flex-metal-seal/>) or equivalent metal seal will be used for sealing between the sealing window assembly and the support flange. The support flange has bolt holes to mount the Configuration B window to a shaking table for vibration testing.

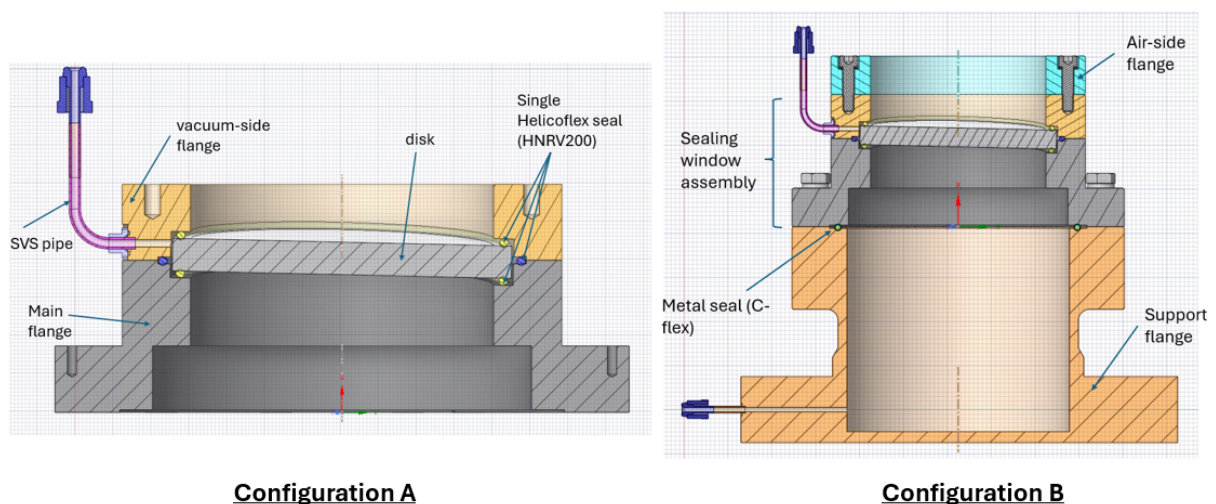

Figure 4 Design of window prototypes

5.3 Qualification program

The sealing assembly samples need to be tested one after another under various aging conditions that replicate those anticipated in the ITER machine. The following diagram, Figure 5 outlines the complete qualification procedure.

Both CV160 Fused Silica and CV130 Quartz windows must undergo this qualification procedure. All five prototypes will be tested in Phase 1. After Phase 1, four aged prototypes will

Service

be used for Phase 2 tests—one per test. The required window configuration for each test is shown in Figure 5.

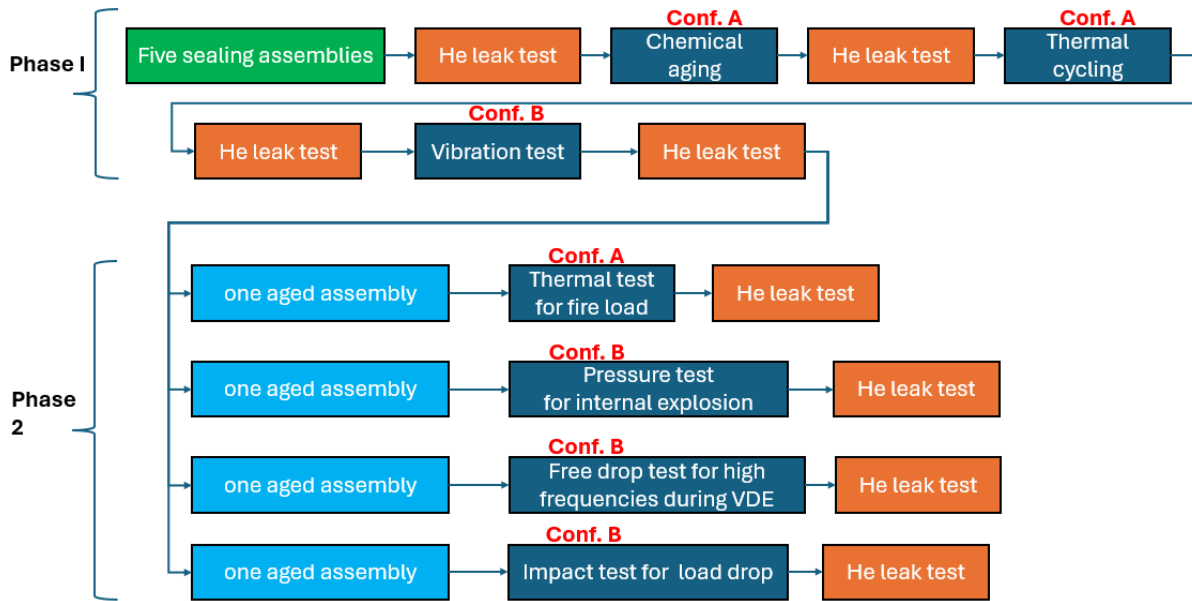

Figure 5 Qualification test sequence of the window sealing assembly

5.4 Free-issue items

IO will provide to the Contractor the window prototypes listed in Table 1.

Table 1 – List of window prototypes provided by IO

ID	Window prototypes		quantity
WP001	CV160 Fused Silica	Window mock-up	5
WP002		Configuration B parts	3
WP003	CV130 Quartz	Window mock-up	5
WP004		Configuration B parts	3

6 Technical requirements

- [RQ-0001] Five window prototypes shall complete Phase 1 tests in Figure 5 for both CV160 Fused Silica and CV130 Quartz windows.
- [RQ-0002] The prototypes aged during Phase 1 shall be used for Phase 2 test in Figure 5. One prototype needs to be used per test, while one prototype can be kept as spare.
- [RQ-0003] He leak test shall be conducted before and after each test according to [RD2].
- [RQ-0004] The Contractor is required to perform testing of all ten prototypes simultaneously for chemical aging and thermal cycling to reduce testing time.
- [RQ-0005] The Contractor shall prepare a detailed procedure for each test and get approval from IO before starting testing.

Service

6.1 Chemical aging test

The objective of the chemical aging test is to assess the resistance of the window sealing assembly (optic disk + Helicoflex metal gasket interface and associated metallic parts in contact) to wet immersion conditions representative of ITER coolant ingress events, and to verify that the sealing assembly maintains the required leak tightness after exposure.

[RQ-0006] A visual inspection of each specimen is required and initial condition should be documented (photos of sealing interface regions and metallic surfaces).

[RQ-0007] The water meeting the chemistry requirements in Table 2 shall be used as immersion medium.

[RQ-0008] The test should follow the following procedure:

1. Stabilize immersion bath at 90 °C before introducing specimens.
2. Place specimens in holders to avoid contact with tank walls/other specimens.
3. Fully immerse specimens, start exposure timer, and maintain temperature throughout the full 20 days. The VCR connector of the SVS pipe should be sealed.
4. Monitor and record bath temperature continuously (or at a defined interval suitable for qualification records).
5. Maintain water chemistry within the limits in Table 2 **Error! Reference source not found.**; if corrective action is needed (e.g., water replacement), record the event and re-verify chemistry compliance.
6. Remove specimens and allow excess water to drain at the end of exposure.
7. Rinse with demineralized water to remove residues.
8. Dry using clean, lint-free wipes and/or filtered air; avoid abrasive cleaning of sealing surfaces.
9. Allow specimens to stabilize at ambient laboratory conditions prior to inspections and leak testing (typically 1 ~ 24 h depending on facility practice), ensuring no residual surface water influences the leak test set-up.

[RQ-0009] After completing the test, the prototypes shall be inspected visually for any defects (corrosion products / discoloration on metallic parts, stains or deposits at the sealing interface, surface changes on the optic disk near the seal contact, any evidence of degradation that could affect sealing) and the results shall be documented with photos.

[RQ-0010] After chemical aging, each prototype shall undergo helium leak testing to confirm the sealing assembly still meets the specified leak tightness requirements (1×10^{-10} Pa·m³/s air-equivalent).

[RQ-0011] The test report shall include:

- Specimen IDs and configuration,
- Calibration certificates of equipment and instruments
- Immersion start/end date-time and total duration (20 days)
- Temperature record demonstrating 90 °C exposure
- Measured water chemistry results (baseline, intermediate, final) demonstrating compliance with limits in Table 2
- Visual inspection findings with photographs (before/after)
- Helium leak test procedure reference and measured leak rates before/after aging

Table 2 Water chemistry parameters for chemical aging

Parameter	Unit	Limit
Conductivity @25°C	µS/cm	≤ 1
Acidity @25°C	pH	6.5 – 9.0

Service

Chloride	ppm	≤ 15
Catalyzed Hydrazine	ppm	≤ 0.05
Ammonia	ppm	≤ 1
Oxygen	ppm	≤ 35
ORP @ 25oC	mV	(- 400) ~ (-100)
Iron	ppb	≤ 12
Copper	ppb	≤ 13

6.2 Thermal cycling test

The objective of the thermal cycling test is to evaluate the ability of the sealing assembly to withstand repeated high- and low-temperature excursions representative of ITER operational conditions, baking cycles, and accidental temperature excursions. The test verifies that the sealing assembly maintains leak tightness and does not undergo mechanical degradation after repeated thermal stresses.

[RQ-0012] Thermal cycling chamber(s) shall be compliant with the following requirements:

- Programmable thermal cycling chamber capable of 20–240 °C range
- Temperature control accuracy: ± 5 °C
- Logging capability ≥ 0.1 Hz sampling
- Fixtures ensuring full mechanical representativeness and no constraint that alters thermal expansion behavior

[RQ-0013] At least two thermocouples shall be attached to the sealing assembly: one on the disk and one on the metal parts adjacent to the seal.

500 thermal cycles shall be conducted as per the thermal cycling conditions defined in

[RQ-0014] Table 3.

Table 3 Thermal cycling conditions for thermal aging test

Phase	No. of cycles	Thermal cycling conditions
Phase 1	5	20°C – 240°C within 8 hours. Dwell time : 1 hours 240 – 20°C within 8 hours
Phase 2	50	20°C to 160°C within 1.0 hour Dwell time : 0.5 hour 140°C to 20°C within 2 hours
Phase 3	440	70°C – 160°C within 0.75 hour Dwell time : 1 hour 140°C – 70°C within 1.5 hours
Phase 4	5	20°C – 240°C within 8 hours. Dwell time : 1 hours 240 – 20°C within 8 hours
Phase 5	100	20°C – 80°C within 0.5 hour Dwell time : 1 hour 80°C – 20°C within 1 hours

[RQ-0015] He leak test shall be performed as follows:

Service

- After Phase 1
- After Phase 2
- Every 110 cycles during Phase 3
- After Phase 4
- After Phase 5

[RQ-0016] The acceptance criterion for the He leak test is 1×10^{-10} Pa·m³/s (air equivalent).

[RQ-0017] After completing all cycles, visual inspection is required to check for cracking, disk/seal interface abnormalities, etc.

[RQ-0018] The test report shall include:

- Specimen IDs and configuration,
- Calibration certificates of equipment and instruments
- Total number of cycles completed
- Representative temperature record for each Phase, including records for temperature deviation $> \pm 5$ °C
- Helium leak test procedure reference and leak test results
- Visual inspection findings with photographs

6.3 Vibration tests

Mechanical cycling tests are performed to qualify the window sealing assembly against the dynamic loads expected during ITER lifetime, including:

- Seismic events (0–35 Hz) and
- Electro-magnetic events (e.g., VDE-induced vibrations, up to ~2000 Hz)

The tests shall demonstrate that, after completion of the mechanical cycling campaign, the sealing assembly maintains leak tightness and does not exhibit mechanical degradation that could compromise its confinement function.

[RQ-0019] The following standards shall be used as test method standards (procedure and reporting framework). The test severities (FRS/ZPA) remain those defined in this document:

- IEC 60068-2-6 - Environmental testing, Test Fc: Vibration (sinusoidal)
- IEC 60068-2-64 - Environmental testing, Test Fh: Vibration, broadband random and guidance
- IEC 60068-2-47 - Mounting of specimens for vibration, impact and similar dynamic tests
- IEC 60068-2-57 - Vibration, time-history and sine-beat method (for time-history control)

[RQ-0020] For the vibration testing, the prototypes shall be reconfigured to the Configuration B.

[RQ-0021] Specimen shall be mounted in a way that reproduces the in-service boundary conditions as closely as practical (bolt pattern, stiffness, load path).

[RQ-0022] Fixtures shall be designed to avoid unrealistic stiffening; fixture dynamic behaviour shall be characterized and documented.

[RQ-0023] Control accelerometers shall be installed at the shaker table control points (one per driven axis).

[RQ-0024] Response accelerometers shall be installed at representative locations on the specimen (support plate + window body) to monitor transmissibility and identify resonances.

[RQ-0025] The Contractor shall record:

- control and response acceleration time series, and

Service

- the achieved spectra (FRS match plots, PSD plots, or sweep curves), as applicable.
- [RQ-0026] Pre-test resonance search shall be performed using a low-level sine sweep to confirm that the setup is stable and to identify resonances (per IEC 60068-2-6 practice).
- [RQ-0027] The vibration test report shall include:
- Prototype IDs and configuration, photos, mounting/fixture description (IEC 60068-2-47)
 - method used per test block (time-history per IEC 60068-2-57 or random per IEC 60068-2-64; sine per IEC 60068-2-6)
 - Calibration certificates of equipment and instruments
 - achieved input evidence (FRS match plots / PSD plots / sine sweep traces)
 - response accelerometer data and identified resonances
 - all intermediate inspections and helium leak test results
 - any deviations and corrective actions.

6.3.1 Vibration tests for seismic events

The objective is to perform mechanical cycling representative of seismic events, using the FRS at the window interface. Tri-axial simultaneous excitation is required for SL-1 and SL-2 event, respectively.

[RQ-0028] The following test inputs shall be applied:

- Target: Enveloping FRS for SL-1 & SL-2 at window interface in Appendix I
- Shaking duration for SL-1 event: 150 seconds which are equivalent to 5 SL-1 events (a duration of 30 seconds per SL-1 event is adopted, which envelopes the strong motion content of representative ITER seismic records)
- Shaking duration for SL-2 event: 30 seconds

[RQ-0029] The Contractor may use either method, provided the achieved response at control points matches the target envelope:

- Method 1 - Time-history control (IEC 60068-2-57): generate tri-axial acceleration time histories whose response spectra envelop the target FRS, apply simultaneously in X/Y/Z
- Method 2 - Random/PSD control (IEC 60068-2-64): convert the FRS specification to an equivalent PSD control profile by an agreed conversion method, then apply tri-axial broadband random vibration to achieve the target severity

[RQ-0030] The test shall be performed in the following steps:

- Mount prototypes and verify instrumentation
- Perform low-level resonance search (sine sweep) to confirm stability
- Execute one tri-axial run representing SL-1 events, using either permitted control method above
- After SL-1 event run, perform visual inspection and verify of bolted joints (no loosening)
- Leak test checkpoint: perform helium leak test at the end of the SL-1 run. The acceptance criterion is 1×10^{-10} Pa·m³/s (air equivalent).
- Execute one tri-axial run representing SL-2 event
- After SL-2 event run, perform visual inspection and verify of bolted joints (no loosening)
- Leak test checkpoint: perform helium leak test at the end of the SL-2 run. The acceptance criterion is 3.2×10^{-5} Pa·m³/s (air equivalent).

Service

6.3.2 Vibration tests for VDE events at low frequency (<100Hz)

The objective is to perform unidirectional low-frequency vibration testing using the FRS specified for VDE events, limited to <100 Hz, consistent with the qualification approach [RD1] that high-frequency spectra are uncertain and therefore treated separately.

[RQ-0031] The following test inputs shall be applied:

- Target: FRS for VDE II & VDE IV at the window interface in Appendix I
- Frequency band: <100 Hz (the frequency band to be increase as high as possible, depending on shaking table capacity)
- Shaking duration for VDE II: 1.5 hours per axis to represent 3300 VDE events by a condensed vibration exposure (4 x 36ms x 10 cycles/event x 3300 cycles). This duration is selected to provide equal or greater cumulative fatigue damage than the lifetime event set, while maintaining the specified PSD severity.
- Shaking duration for VDE IV: 10 seconds per axis

[RQ-0032] The Contractor may use either Time-history control (IEC 60068-2-57) or Random/PSD control (IEC 60068-2-64), provided the achieved response at control points matches the target envelope.

[RQ-0033] The test shall be performed in the following steps:

- Mount prototypes and verify instrumentation
- Perform low-level resonance search 5 – 100 Hz
- Apply the specified low-frequency excitation unidirectionally in each direction (X, Y, Z) for VDE-II event
- After VDE-II event run, perform visual inspection and verify of bolted joints (no loosening)
- Leak test checkpoint: perform helium leak test at the end of the VDE-II run. The acceptance criterion is 1×10^{-10} Pa·m³/s (air equivalent).
- Apply the specified low-frequency excitation unidirectionally in each direction (X, Y, Z) for VDE-IV event
- After VDE-IV event run, perform visual inspection and verify of bolted joints (no loosening)
- Leak test checkpoint: perform helium leak test at the end of the VDE-IV run. The acceptance criterion is 3.2×10^{-5} Pa·m³/s (air equivalent).

6.3.3 Sinusoidal vibration tests for VDE events at high frequency (100-2000 Hz)

The objective is to perform high-frequency vibration testing in each direction using sine sweep in the range 100–2000 Hz, with the ZPA specified in Appendix I.

[RQ-0034] The test shall be performed in the following steps:

- Perform a low-level pre-sweep 100–2000 Hz to identify resonances and confirm safe operation.
- Execute the qualification sine sweep 100–2000 Hz at the specified ZPA level for that axis.
- If a dominant resonance is identified (high transmissibility), the Contractor must apply an endurance dwell at that frequency following IEC 60068-2-6 guidance for fixed-frequency endurance. The dwell shall be performed at the qualified acceleration level (ZPA) for a duration of 2 minutes per dominant resonance per axis which provides at least 30,000 cycles (= 250Hz x 60s) at each dominant resonance, given that the window natural frequency is > 250Hz.
- Repeat for each orthogonal axis

Service

- Leak test checkpoint: perform helium leak test after completing high-frequency sweeps. The acceptance criterion is 1×10^{-10} Pa·m³/s (air equivalent).
- [RQ-0035] A sweep rate in the range 0.5 to 1 octave per minute is acceptable, depending on specimen dynamic response and test facility capability.

6.4 Thermal test for fire load

The objective of the thermal test for fire load is to demonstrate that the window sealing assembly maintains its confinement and sealing function when exposed to thermal conditions representative of an internal fire event in ITER.

[RQ-0036] The Contractor must use one aged sealing assembly prototype which has successfully completed Phase 1 testing. At least two TCs should be attached to the prototype to monitor temperature during testing: one on the disk and one on the metal part adjacent to the sealing interface. And a Helium leak detection system shall be connected to the SVS pipe to monitor leak tightness continuously during the test. See Figure 6.

[RQ-0037] Before starting the test, the Contractor shall verify calibration status of oven temperature control, TCs and He leak detector. A baseline He leak test should be performed at ambient temperature and the results need to be recorded. It is also important to confirm correct installation of TCs and leak test connection.

[RQ-0038] The test shall be performed in the following steps:

- Preheat the oven to 300 °C and stabilize temperature.
- Once stabilization is confirmed, carefully insert the sealing assembly into the oven.
- Start temperature and helium-leak data recording immediately.
- Maintain the sealing assembly at 300 °C for a duration of 2 hours.
- During the soak, continuously monitor and record sealing assembly temperature and helium leak rate. No active thermal cycling or mechanical loading is applied during this phase.
- After completion of the 2-hour soak, switch off oven heating.
- Allow the sealing assembly to cool naturally inside the oven down to near-ambient temperature.
- Continue helium leak monitoring throughout the entire cool-down period. Forced cooling is not permitted, as it may introduce non-representative thermal stresses.

[RQ-0039] The acceptable He leak rate is 3.2×10^{-5} Pa·m³/s (air equivalent) during and after the test.

[RQ-0040] The test report shall include:

- Prototype ID and configuration,
- Calibration certificates of equipment and instruments
- temperature-time history,
- helium leak rate history,
- any anomalies observed.

Service

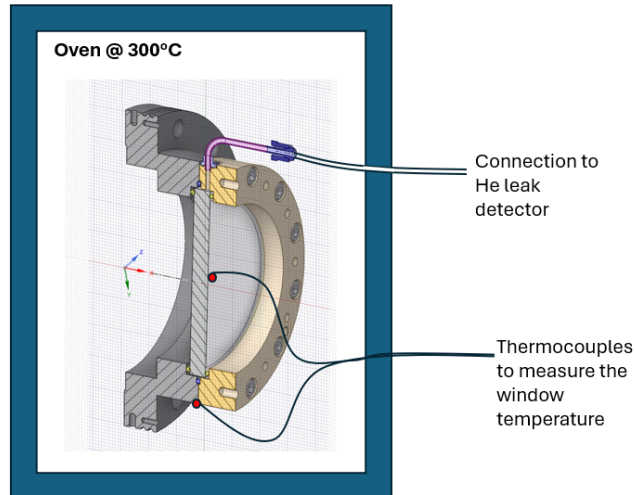

Figure 6 Schematic of the thermal testing for fire load

6.5 Pressure test for internal explosion

The objective of this test is to demonstrate that the window sealing assembly maintains its safety confinement function when subjected to an internal explosion scenario, represented by a sudden pressure increase in the vacuum vessel following an internal fire event.

[RQ-0041] The Contractor must use one aged sealing assembly prototype which has successfully completed Phase 1 testing. At least two TCs should be attached to the prototype to monitor temperature during testing: one on the disk and one on the metal part adjacent to the sealing interface. And a Helium leak detection system shall be connected to the SVS pipe to monitor leak tightness continuously during the test. See Figure 6. A compressor (pressure supply system) shall be connected to the SVS pipe to pressurize the volume enclosed with the disk and the metal parts. See Figure 7. The pressure control and relief system is required to ensure safe pressure ramp-up and protection against over-pressurization.

[RQ-0042] Before starting the test, the Contractor shall verify calibration status of oven temperature control, pressure transducer, TCs and He leak detector. A baseline He leak test should be performed at ambient temperature and the results need to be recorded. It is also important to confirm correct installation of pressure ports, TCs and leak test connection.

[RQ-0043] The test shall be performed in the following steps:

- Preheat the oven to 250 °C.
- Stabilize the oven temperature.
- Insert the sealing assembly into the oven.
- Start continuous recording of temperature and helium leak rate.
- Maintain the sealing assembly at 250 °C for 2 hours.
- Monitor and record temperature stability and helium leak rate throughout the soak period.
- Pressure shall be applied while the sealing assembly remains at elevated temperature.
- Apply a static proof pressure of 2 bar to the inner side of the window assembly.
- Maintain 2 bar pressure for a minimum of 5 minutes.
- Continuously monitor and record applied pressure and helium leak rate.
- Increase the pressure from 2 bar to 4 bar in a controlled manner (no shock loading).
- Maintain 4 bar pressure for a minimum of 5 minutes.
- Continuously monitor and record applied pressure and helium leak rate.

Service

- Gradually release the applied pressure back to ambient.
- Switch off oven heating.
- Allow the sealing assembly to cool naturally inside the oven down to ambient temperature.
- Continue helium leak monitoring throughout the cool-down phase.

[RQ-0044] The acceptable He leak rate is 3.2×10^{-5} Pa·m³/s (air equivalent) during and after the test.

[RQ-0045] The test report shall include:

- Prototype ID and configuration,
- Calibration certificates of equipment and instruments
- temperature-time history,
- pressure-time history,
- helium leak rate history,
- any anomalies observed.

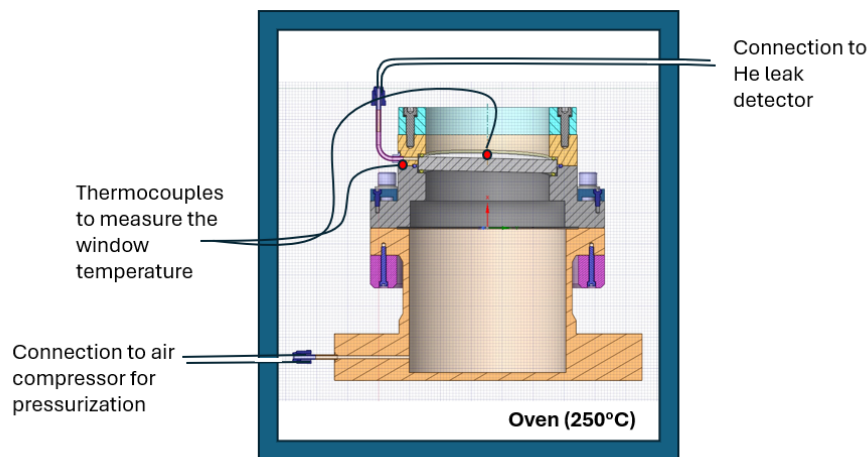

Figure 7 Schematic of pressure test for internal explosion

6.6 Impact test for load drop

The objective of this test is to demonstrate that the aged diagnostic window assembly / sealing assembly can withstand a load drop impact representative of maintenance activities, corresponding to IK10 impact energy (20 J), and still maintain the required leak tightness.

[RQ-0046] The Contractor must use one aged sealing assembly prototype which has successfully completed Phase 1 testing. Configuration B are to be used for the impact test.

[RQ-0047] Three impact locations are determined by considering areas that are vulnerable to impact or likely to be subjected to impact. They are identified in Figure 8. These locations should be marked clearly on the prototype and recorded in the test report with photos and coordinates.

[RQ-0048] Impact test apparatus compliant with IEC 60068-2-75, capable of delivering 20 J impacts using one of the permitted methods (facility-dependent), e.g., pendulum hammer method, or vertical/free-fall impact method.

[RQ-0049] The prototype should be mounted to a rigid base and fixed to prevent movement of the specimen during impact.

[RQ-0050] The test procedure should be compliant with ICE 60068-2-75. The following execution steps are to be repeated for each location.

Service

- Position and align the hammer striker at location i.
 - Deliver Impact #1 (20 J).
 - Perform a quick check for: obvious cracking, spalling, gross deformation, fixture looseness, loss of stable mounting.
 - Deliver Impact #2 (20 J) at the same location.
 - Repeat the quick check.
 - Deliver Impact #3 (20 J) at the same location.
 - Photograph the impacted area before proceeding to the next location.
- [RQ-0051] After completing the impact test, visual inspection should be performed to check conditions of each impacted area and surrounding regions: cracks, fractures, chipping, permanent deformation, loosened fasteners, displacement of sealing-related parts. All impacted areas and overall assembly are to be photographed.
- [RQ-0052] He leak test shall be performed after completion of the impact test using the approved procedure. The acceptance criterion is $1 \times 10^{-10} \text{ Pa} \cdot \text{m}^3/\text{s}$ (air equivalent).
- [RQ-0053] The test report shall include:
- Prototype ID and configuration,
 - Test apparatus type (pendulum or vertical impact) and calibration/verification method for 20 J.
 - Calibration certificates of equipment and instruments
 - Impact locations list with photos/coordinates.
 - Number of impacts per location: 3 (and confirmation energy = 20 J).
 - Pre- and post-test inspection results and photographs.
 - Baseline and post-test helium leak results and pass/fail conclusion.

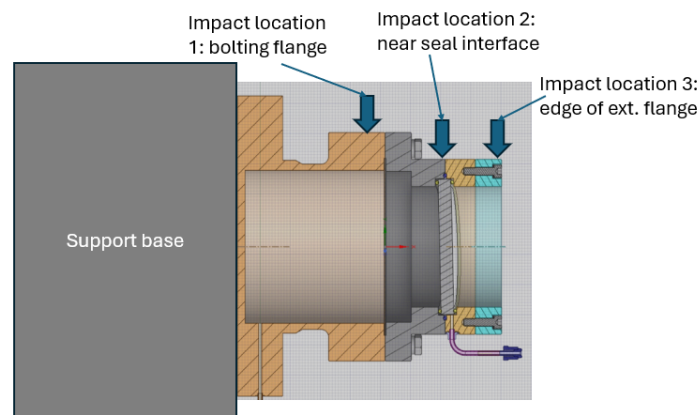

Figure 8 Impact locations

6.7 Free drop test for vibration at high frequencies during VDE

The objective of this test is to evaluate the ability of the aged window assembly (Configuration B) to withstand high-frequency dynamic excitation associated with VDEs in ITER.

The drop test is intended to:

- excite the structure with broad-band, high-frequency content,
- supplement shaking-table tests, for which high-frequency response spectra are uncertain, and
- demonstrate the robustness of the sealing assembly against sudden dynamic excitation after aging.

Service

[RQ-0054] The Contractor must use one aged sealing assembly prototype which has successfully completed Phase 1 testing. Configuration B are to be used for the free drop test.

[RQ-0055] The drop test shall be performed in two orientations: vertical drop (window axis normal to impact surface) and horizontal drop (90° rotation). Only drop per orientation shall be performed. See Figure 9.

[RQ-0056] At least one tri-axial accelerometer shall be installed on the window assembly close to the disk or seal region. Accelerometers must have frequency response up to at least 5 kHz and appropriate dynamic range to capture peak accelerations without saturation. Acceleration signals must be recorded with a sampling frequency sufficient to capture high-frequency content (≥ 20 kHz recommended).

[RQ-0057] The test should be performed in the following steps:

- Raise the prototype to an initial drop height, 50mm.
- Ensure correct alignment for the vertical drop in Figure 9 and absence of pre-loading or constraint.
- Release the prototype to impact the rigid surface freely.
- Record acceleration time histories in all instrumented directions.
- Repeat the test for the horizontal drop.
- Increase the drop height by 50mm and repeat the free drop in both orientations.
- After each drop, inspect the specimen for visible damage and verify fixture integrity and instrumentation.
- Continue increasing the drop height until one of the following occurs:
 - The drop height reaches 200mm
 - Glass crack is observed,
 - Loss of leak tightness (3.2×10^{-5} Pa·m³/s (air equivalent)) is detected.

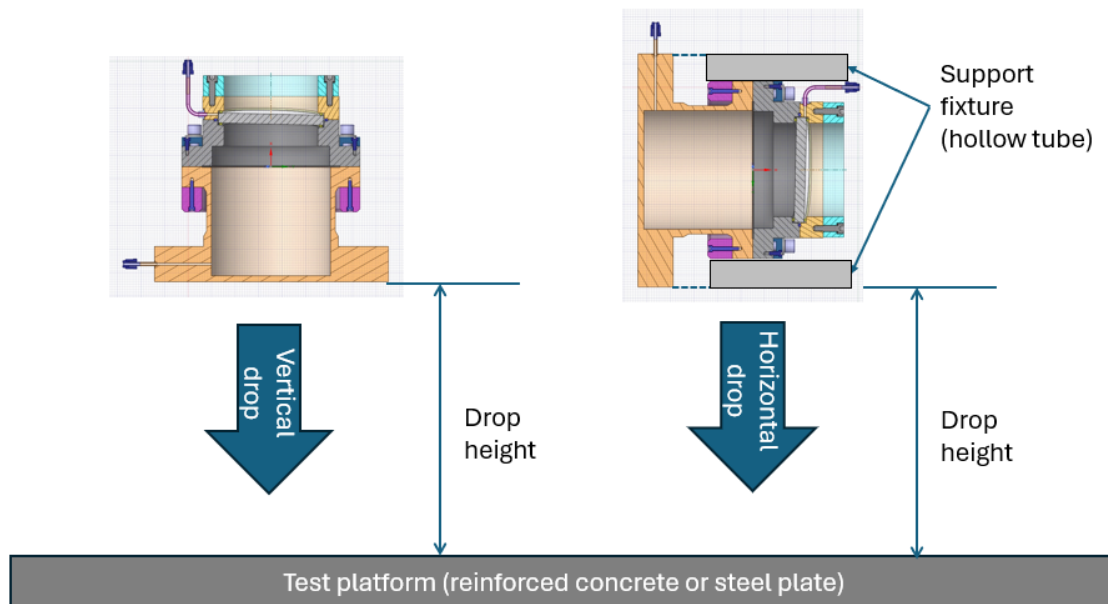

Figure 9 Schematic of free drop test set up

[RQ-0058] The test report shall include:

- Specimen ID and configuration,
- Calibration certificates of equipment and instruments

Service

- Drop heights and corresponding measured accelerations,
- Acceleration time histories,
- Pre- and post-test leak rates,
- Visual inspection findings,
- Identification of limiting drop height, if applicable,
- Conclusions regarding qualification against high-frequency VDE loads.

6.8 Actions to be implemented in case of thermal cycling test failure

If a test fails due to poor execution, the result should be disregarded and the test must be repeated. To prepare for this case, IO will provide two additional spare disks.

If the thermal cycling test is properly performed but the required leak tightness cannot be achieved, the test should be conducted by following the test sequence in Figure 10.

If a leak rate is observed above the threshold detectable by SVS monitoring, specifically $5 \times 10^{-6} \text{ Pa} \cdot \text{m}^3 \cdot \text{s}^{-1}$ [RD4], the tested prototype should be withdrawn from the cycling campaign after 50 extra thermal cycles - the maximum interval between ITER long-term maintenance. Then, the prototype should be subjected to thermal test for fire load in Section 6.4 and pressure test for internal explosion in Section 6.5 to check if it can withstand the category 4 event conditions before its next scheduled replacement.

This approach verifies that an assembly identified by SVS as not meeting vacuum standards still fulfil safety requirements, so early replacement before shutdown is unnecessary.

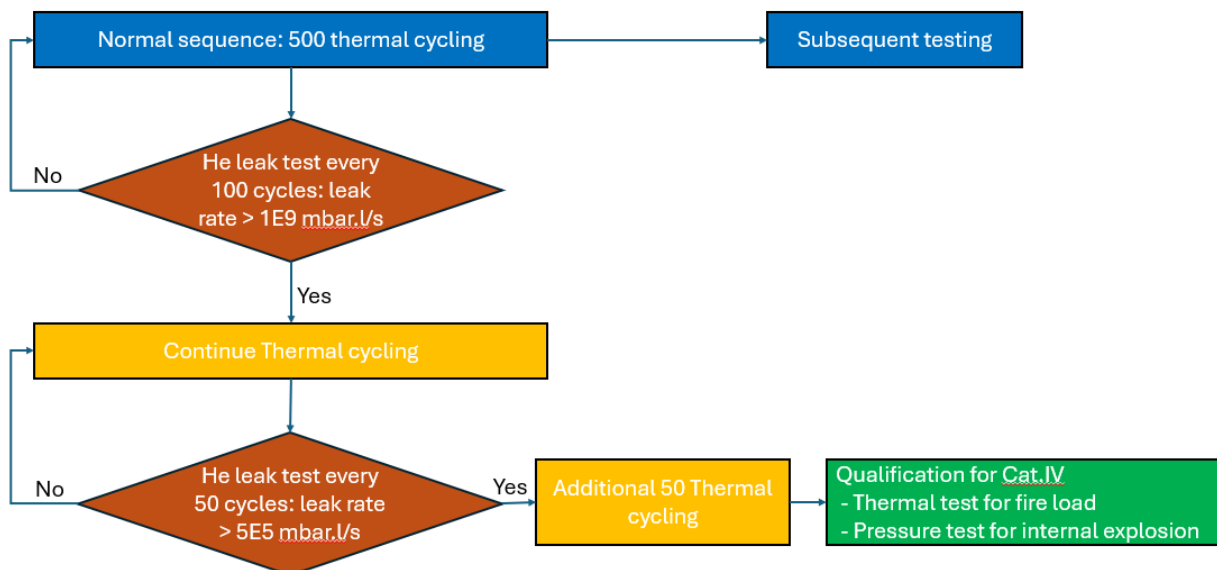

Figure 10 Modification of the test sequence in case of test failure during thermal cycling

7 Deliverables and Schedule Milestones

The maximum expected duration from the contract signature to the supply of the scope of work is [16] months. The Supplier shall provide IO with deliverables listed in Table 4.

As presented in Figure 11, all the tests in Section 6.4, 6.5, 6.6 & 6.7 should be carried out in parallel after aging tests (chemical, thermal cycling, and vibration).

Service

Table 4 - List of deliverables and delivery due dates

#	Category	PIA	Deliverables	Further Description	Delivery due date (T0+x)*
D1	Project Management	No	-Verification Control Plan (VCP) - Quality Plan (QP) - Detailed work plan and Schedule	- Compliance matrix for requirements - Refer to Section 8	1
D2	Testing	PIA	Qualification Test Plan	Refer to Section 8.1	3
D3	Testing	PIA	Test procedures		3
D4	Testing	PIA	Test results report		14
D5	Delivery	No	Shipping of all prototypes		16

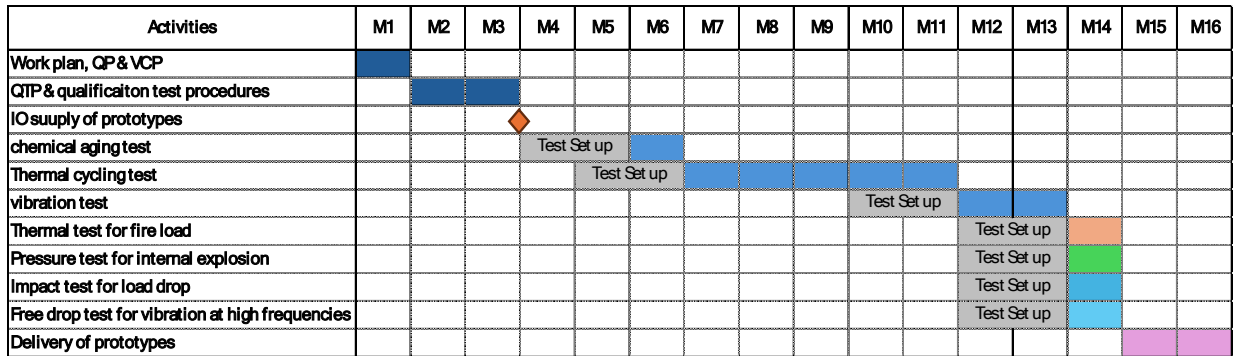

Figure 11 Expected test schedule

8 Quality Assurance requirements

The Quality class under this contract is QC1.

[RQ-0059] The Contractor shall have an ISO 9001 certified quality system or alternatively a QA Program approved by IO QARO. In addition, the quality management system shall comply with the IO quality requirements as per [AD6].

[RQ-0060] The Contractor shall produce its own Quality Plan (QP) and QP of the subcontractors in accordance with [AD6] and submit them to the IO RO for acceptance within 1 month after the KOM.

[RQ-0061] Documentation developed as the result of this Contract shall be retained by the Supplier for a minimum of 5 years and then may be discarded at the direction of the IO.

[RQ-0062] The Contractor shall transmit their document via the IDM system using the IDM Exchange folder area, with the exception of and when applicable:

- Computer-Aided Design (CAD) files that have to be transmitted in the CAD database (SMDD).
- Non-Conformity Report (NCR) that have to be transmitted via the NCR Database.

Service

8.1 Qualification Test Plan

[RQ-0063] Qualification Test Plan (QTP) shall be used to monitor test quality control during the implementation of the Contract.

[RQ-0064] The Contractor shall ensure a close follow-up across their supply-chain, which include their activities as well as their Subcontractors', and Suppliers' when it comes to PIC/PIA. As such, the Contractor shall ensure propagation of requirements to its Subcontractors and Suppliers as needed and define in their QA plan how the Contractor manage the follow-up and inspection of their supply-chain.

[RQ-0065] This monitoring shall include control points at critical steps in the Contractors' plans. The control points shall be integrated into the agreed schedule. QTP shall clearly highlight the PIAs.

[RQ-0066] Drawings, standards, specification, instructions, and the Contractor quality control procedures which are applicable to the test plan shall be clearly identified as to their source, title, number and applicable revision. Reference to a standard and/or specification shall indicate the pertinent chapter, section clause or paragraph and edition. The applicable procedures shall be mentioned for each inspection and testing phase.

[RQ-0067] The Contractor shall not commence testing activities prior to confirmation of test plan's acceptance by the CRO.

[RQ-0068] Any change to an approved QTP shall be resubmitted to the CRO for acceptance.

[RQ-0069] QTP shall list all operations that are critical from a quality point of view. As such, QARO and CRO reserve the rights to request for QTP revision if any activity becomes critical and is not listed in QTP. Typical QTP is available in Appendix I.

[RQ-0070] Several control points shall identify in each MIP:

- **HP (Hold Point)** identifies an operation that must be formally sign-off by an IO or third party representative mandated by the IO before the work continues beyond this point. The work must not continue until the release delivered by IO or/and the Third Party. Where physical witnessing is required for a HP, this must be clearly indicated in the inspection plan for the associated task. IO or Third Party may add a Hold Point to a specific activity at any time during implementation of the work by the Contractor.
- **NP (Notification Point)** identifies an operation/task that must be notified to the IO or a Third Party. IO or Third Party are invited to attend to the operation/task but if they don't attend at the notified time, the work can be proceeded by the Contractor.
- **RP (Registration Point)** identifies an activity where the IO or Third Party not invited to attend but they need to be informed immediately of the results by the Contractor. The information is delivered by the relevant record signed-off by the Contractor. The work can continue when the record has been delivered to IO.
- **W (Witness):** identifies an operation that must be witnessed.
- **S1 (Surveillance 1):** identifies an operation that requires 100% inspection.

Service

- **S2 (Surveillance 2):** identifies an operation that requires random inspection or spot checks.
- **R (Review)** identifies a document that must be reviewed by the IO or Third Party.

[RQ-0071] IO reserve the right to waive partially or in full their attendance and will inform Contractor via their response to Contractor notification for inspection.

[RQ-0072] For Hold Points, Notification Points and Witness Points the Contractor shall notify the inspection body representative at least 2 weeks prior to the implementation of the activity for any operation. When inspection requires overseas travel of IO representative, this notice is extended to 3 weeks. Upon mutual agreement between the different stakeholders, the notification period may be reduced.

[RQ-0073] When an inspection is organised at the Contractor or subcontractor premises, access shall be granted by the Contractor to the premises for IO representative and/or any third party inspectors as designated by ITER Organization.

[RQ-0074] IO attendance to an inspection and/or test phase shall not relieve the Contractor from their own obligation to perform the control and the Contractor Quality Control team is responsible for endorsing the outcome of the inspection and/or test phase.

[RQ-0075] The Contractor shall provide timely and regular reporting on inspection progress. If the Contractor has an online tracking system for their inspection, they shall grant access to IO representative for the test plan follow-up under the Contract. Alternatively, the Contractor shall use IO systems, such as but not limited to: manufacturing database (MDB). In case the Parties agree not to use any system for inspection follow-up, the Contractor shall at least provide the latest test plan dully marked-up as an appendix to their monthly report.

8.2 Audit and other Inspections

If and when required, audits, inspections (further to the one defined in the QTP) and surveillance visits of Contractor's activities or its sub-contractors may be organized by either IO, regulatory bodies or the French Nuclear Authority without prior warning.

The Contractor shall grant access rights to IO, and regulatory body representatives to their offices, facilities and records.

The Contractor shall flow this requirement down to their subcontractors to allow IO, regulatory bodies and the French Nuclear Authority to also perform the above actions in their premises.

8.3 Deviation Request (DR)

The Contractor may raise a Deviation Request to ask for the authorization to depart from a contractual requirement. Deviation Requests shall be approved by IO before implementation of the related activity(ies) (e.g. manufacture of the item).

Deviation Requests shall be managed using IDM IT system (unless agreed differently) from initial submission to closure as defined in section 6.2.2 of [AD1].

Service

8.4 Non-conformity

Any item, process or work that does not fulfil its specified requirements shall be identified and segregated as being nonconforming. Each nonconforming item or work shall be prominently tagged, or uniquely identified and, when practical, segregated to prevent its use. Contractor shall comply with [AD6].

9 Safety requirements

ITER is a Nuclear Facility identified in France by the number-INB-174 (“Installation Nucléaire de Base”).

The components under this contract are Protection Important Components (PIC) and SIC-1 (Safety Important Component) and also include Protection Important Activities for manufacturing and inspection.

A **Protection Important Component (“PIC”)**, as per INB Order Article 1.3, is defined as “a component which is important for protecting the interests mentioned under Article L. 593-1 of the Environmental Code (nuclear security – i.e. nuclear safety, radiation protection, prevention and fight against malicious acts, and also civil security actions in the event of an accident –, public health and sanitation or protection of nature and the environment), i.e. structure, equipment, system (programmed or not), material, component or software that is present in the Basic Nuclear Installation (INB) or that is under the responsibility of the nuclear operator and that implements a function required for the demonstration mentioned under the second paragraph of Article L. 593-7 of the Environmental Code (safety demonstration) or that ensures that this function is implemented.

As per articles 1.3 of the INB Order, a **PIA** is defined as an “Activity important for protecting the interests mentioned under Article L. 593-1 of the Environmental Code (public safety, health and sanitation, the protection of nature and of the environment), i.e. activity that falls under the technical or organizational provisions mentioned under the second paragraph of Article L. 593-7 of the Environmental Code or that is liable to affect them;”

As defined in Article 1.3 of the INB Order, **the Defined Requirements** are “requirement assigned to a protection important component so that it fulfils – with the expected characteristics – the function provided for in the demonstration mentioned in the second paragraph of Article L. 593-7 of the Environmental Code, or to a protection important activity so that it fulfils its objectives as regards this demonstration”. In other words, it means any requirement that has been assigned to a PIC or a PIA so that it may perform the function provided for in the safety demonstration.

[RQ-0076] As the Contract involves PIC or PIA, the Contractor shall comply with all the requirements expressed in “Provisions for implementation of the generic safety requirements by the external actors/interveners” [AD2]. The Contractor shall explain in its quality system or in a dedicated quality plan the measures taken to ensure compliance with these requirements. The Contractor shall ensure the propagation of these requirements to all its subcontractors and/or suppliers involved in PIC or PIA.

[RQ-0077] The Contractor shall put in place a technical control, as defined in Article 2.5.3 of the INB Order, for each PIA. Parties carrying out technical monitoring for a PIA are distinctly separate from the parties who perform the activities.

Service

[RQ-0078] PIAs and their technical control shall be performed according to procedures (demonstration of compliance a priori) and be properly recorded (demonstration of compliance a posteriori).

[RQ-0079] The preliminary PIAs of this contract are listed below. It should be noted that these PIAs need to be updated when preparing QTP.

- Chemical aging test
- Thermal cycling test
- Vibration test
- Thermal test for fire load
- Pressure test for internal explosion
- Impact test for load drop
- Free drop test for vibration at high frequencies

[RQ-0080] The performers of PIAs and of their technical control shall have necessary skill and qualification as per INB order 2.5.5.

[RQ-0081] The Contractor shall ensure that these requirements are propagated to the Subcontractors and Suppliers as needed as per [AD3] and a demonstration of compliance shall be provided upon request of the CRO or SRO. The applicable “Defined Requirements” are provided in Appendix III.

[RQ-0082] The contractor shall be aware of “ITER Policy on Safety, Security and Environment Protection Management” [AD4] and make sure that it is propagated to the sub-contractors.

10 Contract Management

Requirement for [AD1] GM3S section 6 applies in full.

Appendix I - FRS data to be considered for the window qualification

*Note: The FRS in [RD3] is updated to include the new seismic load (PIM-432) [RD5].

Enveloping FRS for SL-1

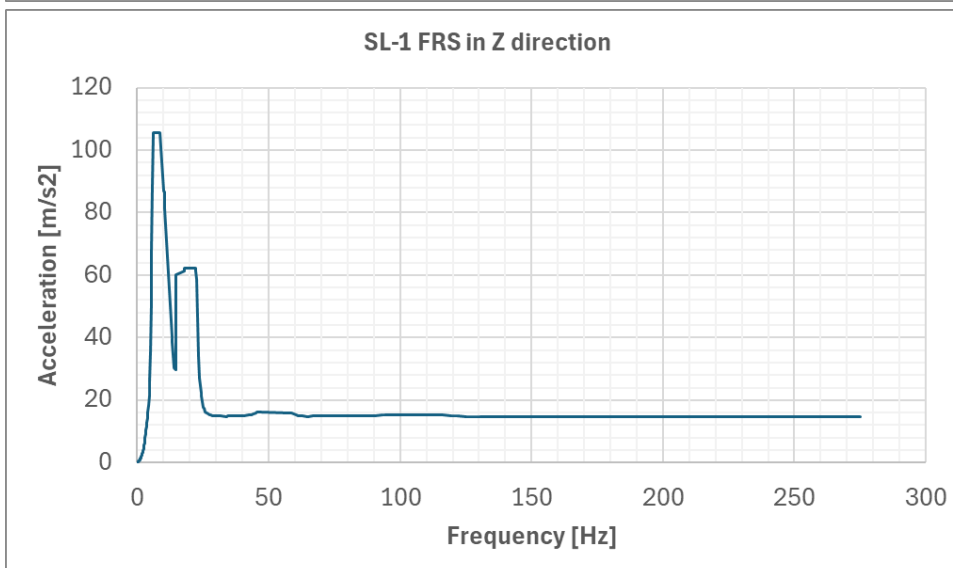
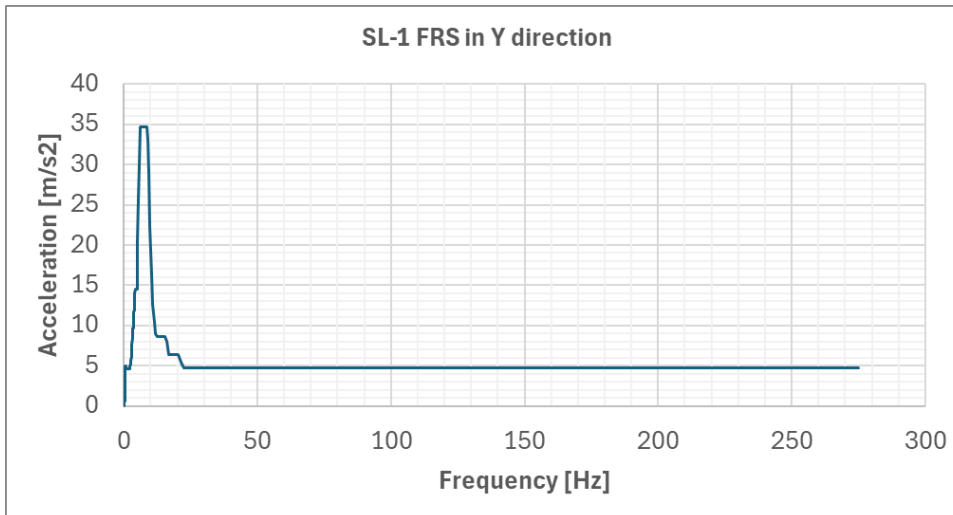
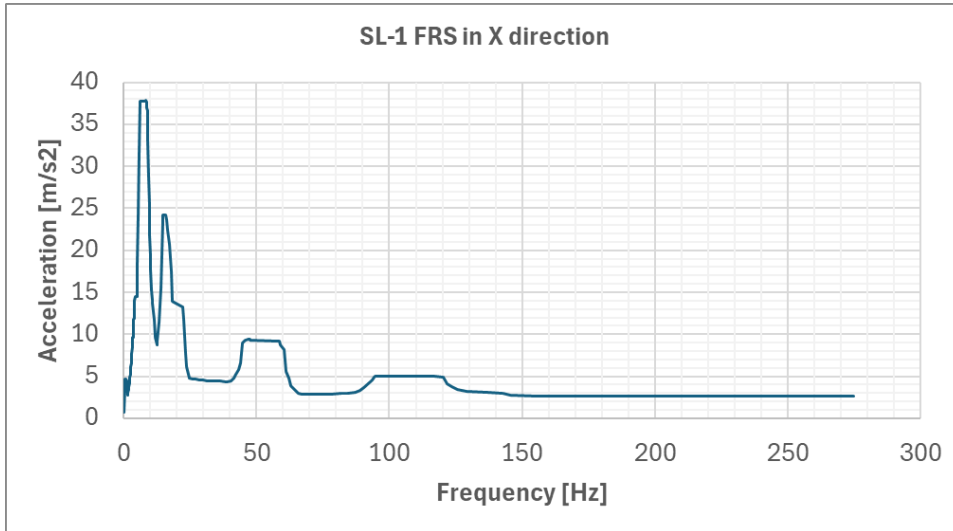

Enveloping FRS for SL-2

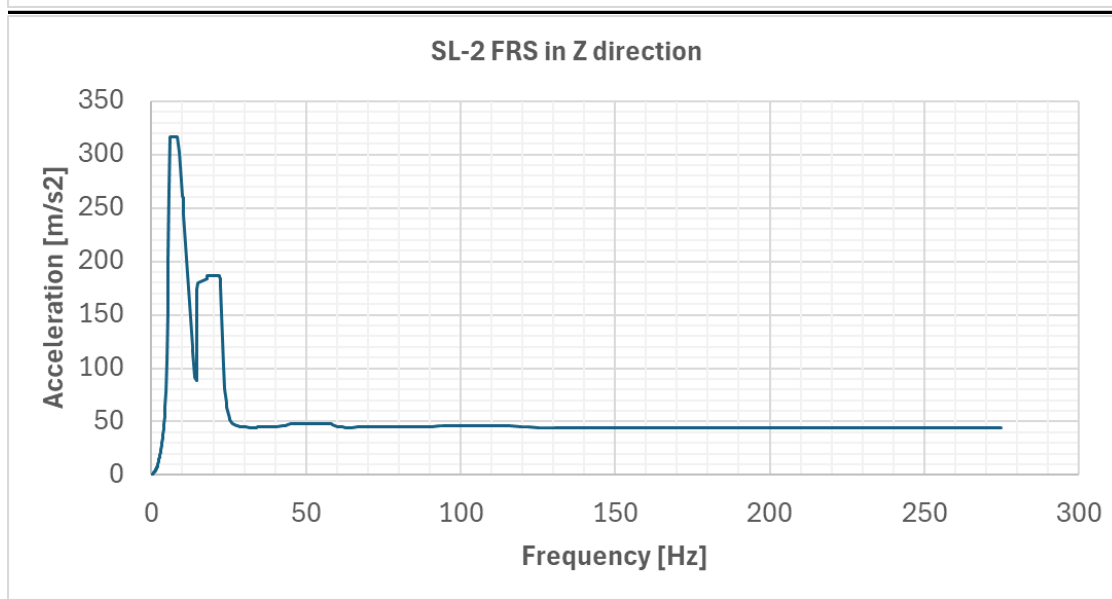
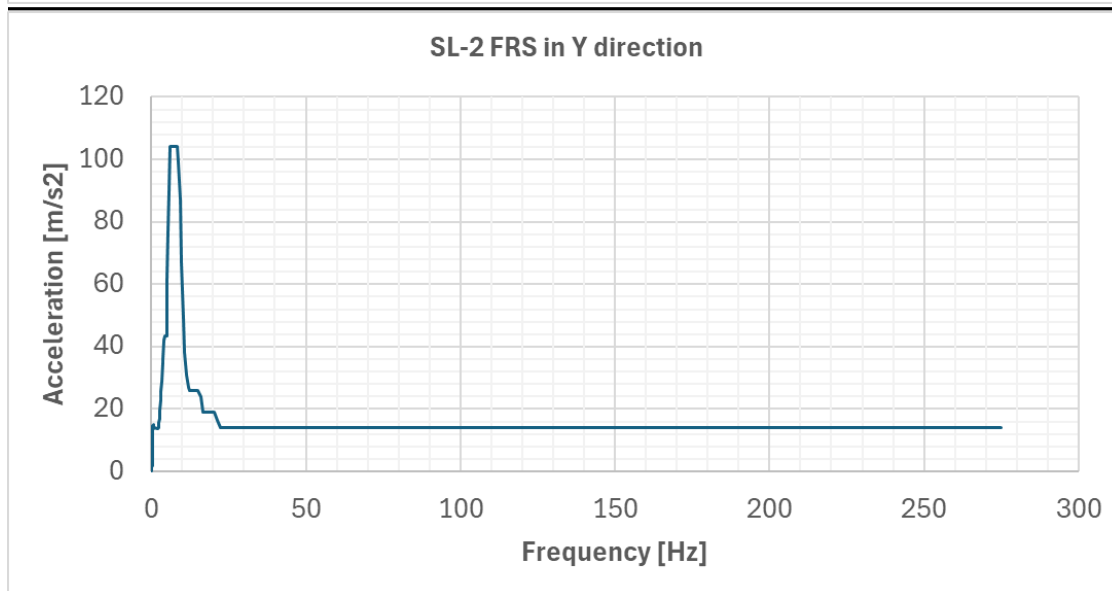
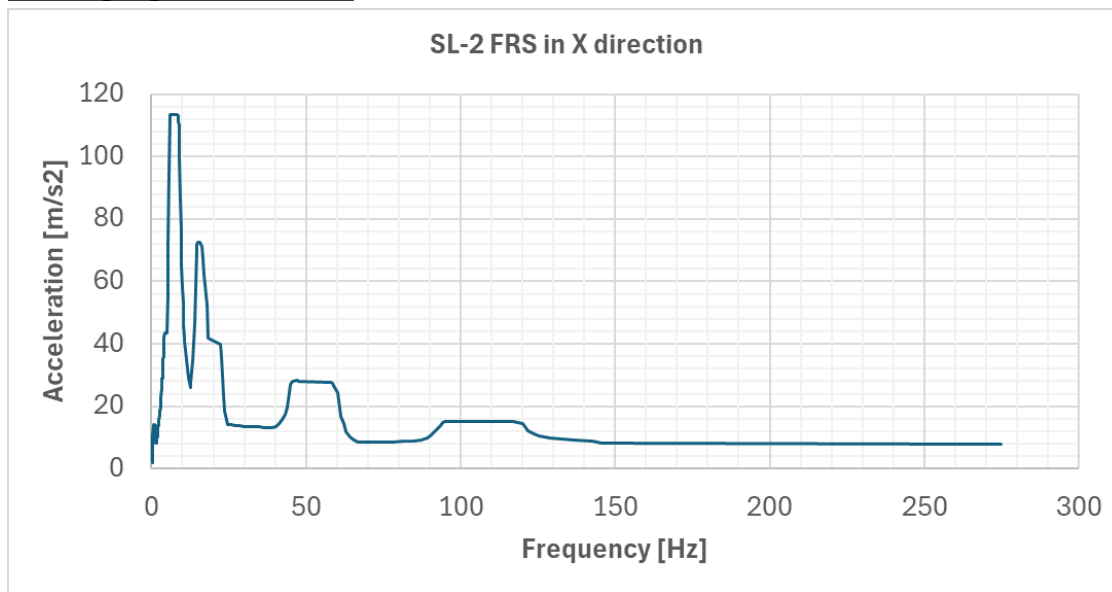

Enveloping FRS for VDE II

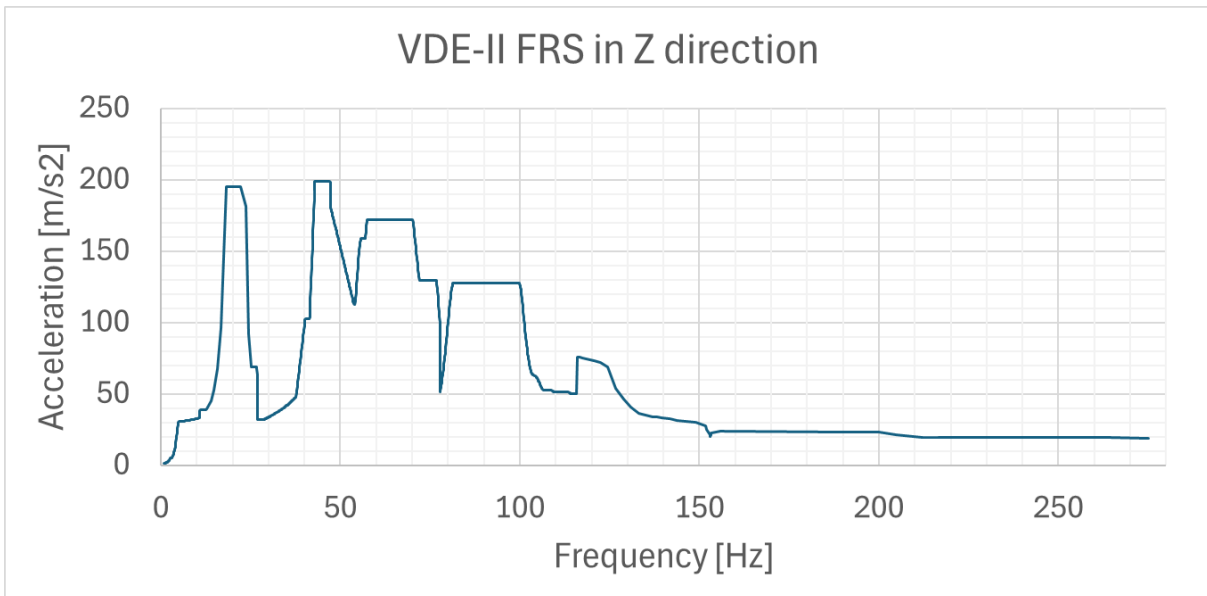
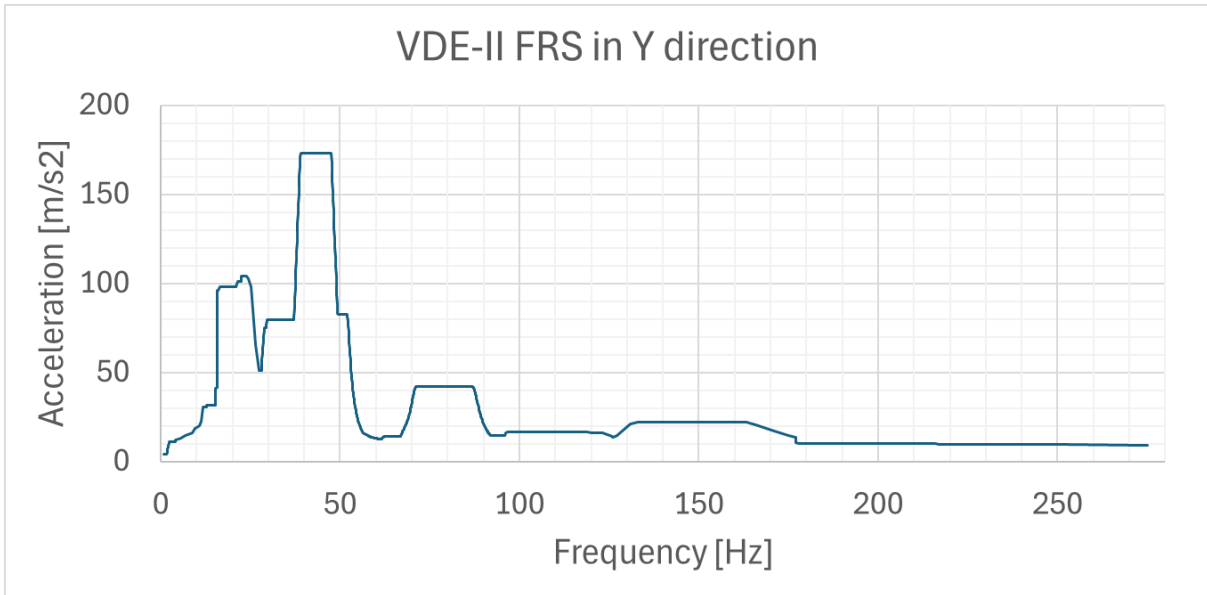
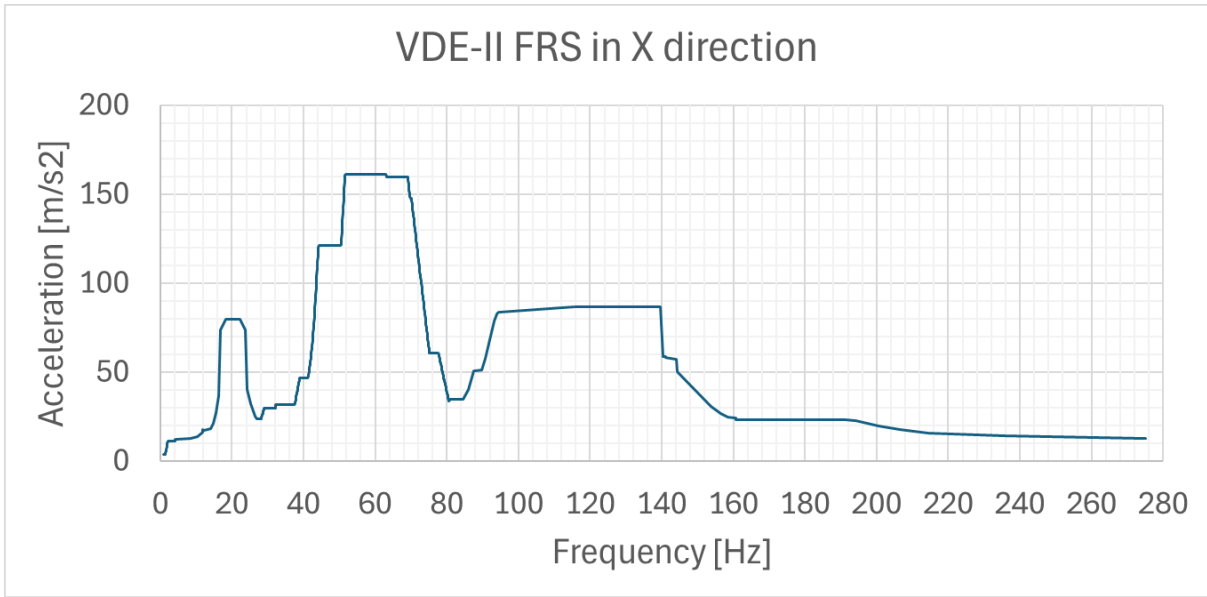

Enveloping FRS for VDE IV

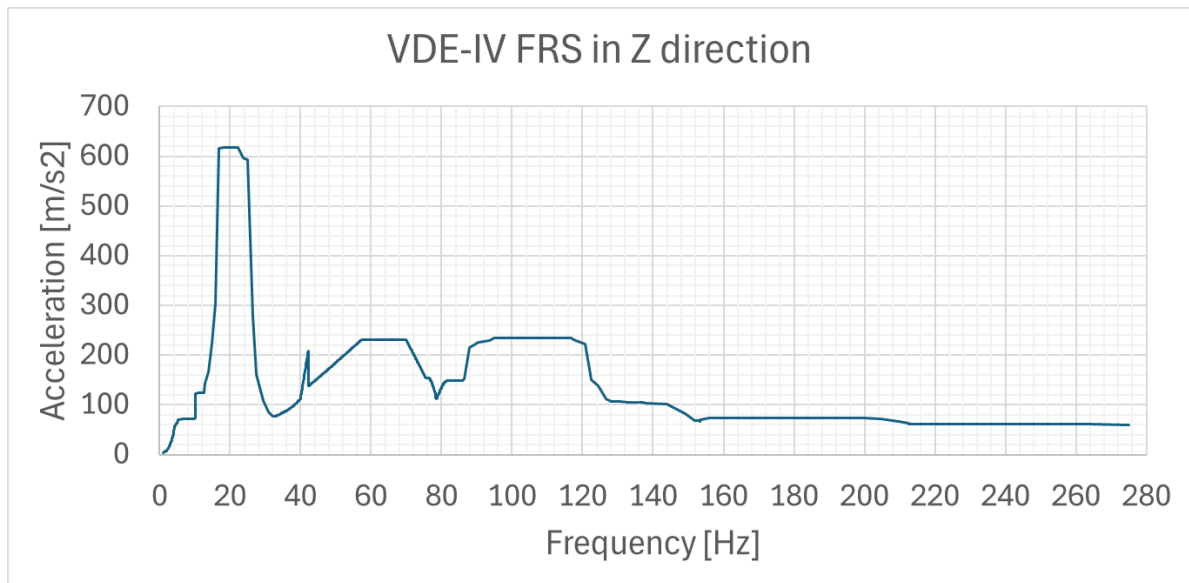
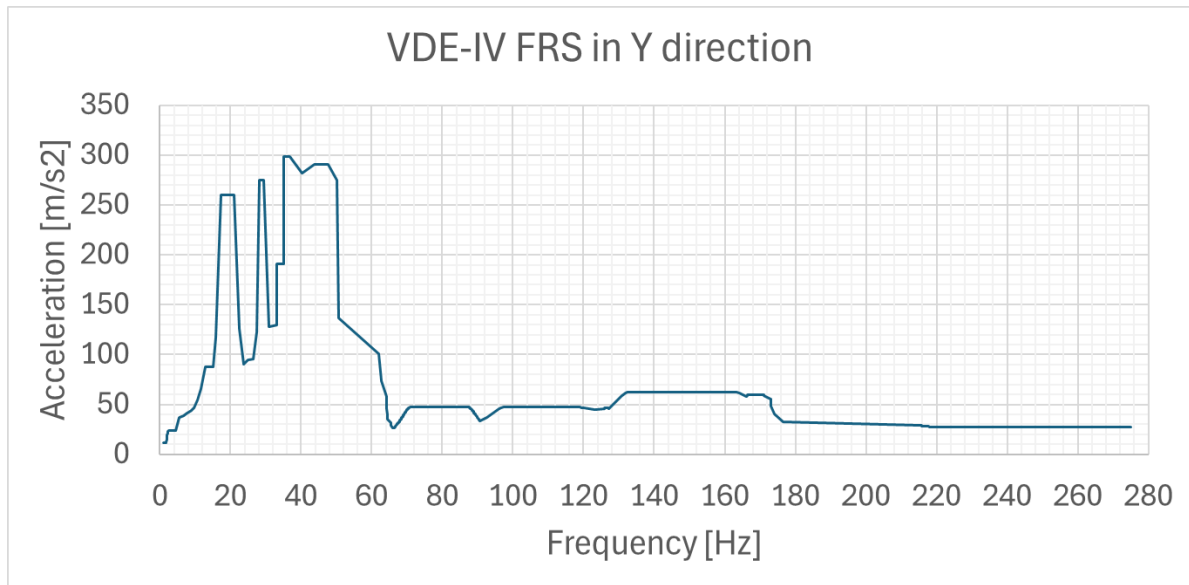
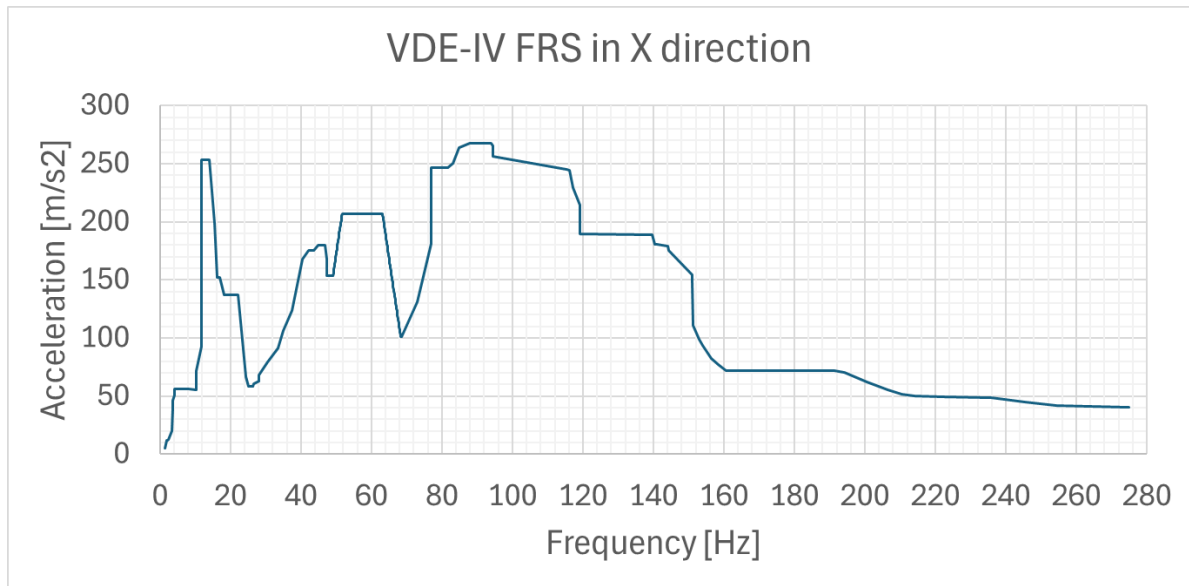

Appendix II – Qualification Test Plan template

Qualification Test Plan																		
Document number:			Revision number:															
ITER PA number:			ITER Contract Number:			Title of item:												
Name of DA/Supplier:			Subcontractor:															
Prepared by Subcontractor Name & Signature:			Approved by Manufacturer Name & Signature:			Approved by DA Name & Signature:			ITER Acceptance Name & Signature:			Control Points: HP: Hold point ATPP: Authorization to Proceed Point NP: Notification Point Standard Activities: W: Witness of Operation S1: 100% inspection, S2 Random inspection R: Report Required D - Recommend Report A: Approve S: Sign Off TC- Technical Control Required						
Position:Supplier Date:			Position: Date:			Position: TRO Date:			Position: Date:									
Operation id	Operations (Manufacture, Inspections & Tests, etc.)	Expected Date	Operation type	PIA? (Y/N)	Subcontractor		Supplier		Inspection Body		IO		Others	Applicable document(s) version UID (K127V5_v1.2)	Applicable Documents or Drawings internal reference	Manufacturing drawing(s) version UID	Records (NCRs, reports, etc.)	Observation(s)
					Name, signature and date	Action	Name, signature and date	Action	Name, Signature and Date	Action	Name, Signature and Date	Action						
1	Header 1																	
1.1	Material preparation						S - Sign Off		S - Sign Off					IDM UID	e.g. HX-FED-DOC-QD-301 Component list	IDM UID		
1.2	Material preparation						NP - Notification Point		NP - Notification Point					IDM UID		IDM UID		
1.3	Material preparation						R - Report Required		D - Recommend Report					IDM UID		IDM UID		
1.4	Material preparation						R - Report Required		D - Recommend Report					IDM UID		IDM UID		
2	Header 2																	
2.1	Material preparation						R - Report Required		D - Recommend Report					IDM UID	e.g. HX-FED-DOC-QD-301 Component list	IDM UID		
2.2	Material preparation						R - Report Required		D - Recommend Report					IDM UID		IDM UID		
2.3	Material preparation						R - Report Required		D - Recommend Report					IDM UID		IDM UID		
2.4	Material preparation						R - Report Required		D - Recommend Report					IDM UID		IDM UID		

Appendix III – Defined Requirements applicable to this contract

SRD ID	Defined Requirements	Propagated Requirements for the supply	Explanation
55NWs1649	<i>The design of 55.NW SIC Structure Systems and Components (SSCs), shall include all loading events for which the SSC may be required to perform a safety function.</i>	<i>Test requirements in section 6</i>	<i>Tests defined to cover all the loading conditions</i>
55NWs1650	PIC components of 55.NW shall be protected against the risk associated with the potential whipping and missile effects from high energy fluid circuits (pressure greater than 20 bar or temperature greater than 100°C) or other potential sources for missiles (such as internal explosion, or failure of a machine with moving parts).	<i>Load drop test in Section 6.6</i>	
55NWs676	<i>Safety functions of the PIC SSCs shall be guaranteed against internal and external aggressions described in the SLS.</i>	<i>Test requirements in section 6</i>	<i>Tests defined to cover all the loading conditions</i>
55NWs686	It shall be demonstrated that the PIC SSCs continue to perform their safety function, for the SL-2 load case as defined in the corresponding Sub-system Load Specification.	<i>Vibration test in Section 6.3.1</i>	
55NWs1657	55.NW PIC components which are part of fire sectors shall avoid propagation of the fire to adjacent zones for 2 hours in areas where radioactivity is present.	<i>Thermal test for fire load in Section 6.4</i>	
55NWs821	It shall be demonstrated by conducting a detailed structural integrity analysis that the SSC continue to perform their safety function for normal and accidental	<i>Test requirements in section 6</i>	<i>Structural integrity analysis has been done for metallic part for safety demonstration. The qualification tests</i>

	load cases according to the component safety component safety function, Codes & Standards and design rules as specified in the different Sub-system Load Specifications [ADc81], [ADc82], [ADc87], [ADc88], [ADc89] and [ADc90]..		<i>specified in this document will demonstrate the safety function of the disks and sealing design which are not covered by the structural analysis.</i>
55NWs1686	55.NW forming parts of the barriers and building penetrations shall resist the effects of accidents such as pressurization failure, explosion, loss of secondary confinement for radioactive inventory, pipe whip, and fire, if failure threatens safety equipment or workers.	<i>Test requirements in section 6</i>	<i>Tests defined to cover all the loading conditions</i>
55NWs1006	For PIC components, assurance of the reliability performance of credited safety functions shall be provided using recognised analysis techniques.	<i>Test requirements in section 6</i>	Aging tests and Cat.IV tests will assure the reliability of the window safety function.
55NWs1692	Penetrations crossing a safety barrier shall reconstitute the barrier properties.	<i>Test requirements in section 6</i>	All the qualification process is aimed at demonstrating that the confinement function will be maintained throughout ITER lifetime.
55NWs1001	Windows shall have a leak rate below the maximum defined in [ADi1], Table 3.1 - including during and after fires.	<i>Test requirements in section 6</i>	Leak rate is specified for each test.
55NWs1074	Vacuum windows (both primary and secondary) shall be pressure tested to demonstrate their ability to withstand 0.2 MPa (off-normal) internally, and proof tested to a pressure of 0.3 MPa.	<i>Test requirements in section 6.5</i>	
55NWs1075	Windows located within VV and Port cell shall comply with the pressure ratings given in [ADi1], Table 3.1.	<i>Test requirements in section 6.5</i>	
55NWs1698	For PIC qualification during/after abnormal events, the cumulative effect of the PIC components' ageing due to their usage and exposure to loads and conditions during their expected lifetime, shall be considered with the	<i>Test requirements in section 6</i>	<i>Tests defined to cover all the loading conditions</i>

	accidental/aggression events occurring at the end of components lifetime.		
55NWs1092	The designers shall verify that PIC components meet applicable defined requirements either by testing or by conduct of sound engineering analyses.	<i>Test requirements in section 6</i>	<i>Tests defined to cover all the loading conditions</i>
55NWs1093	All 55.NW PIC SSCs shall be qualified to the environmental conditions.	<i>Test requirements in section 6</i>	<i>Tests defined to cover the environmental conditions</i>
55NWs265	Data associated with 55.NW PIC functions shall be long term archived in a readable and safe way (protected from internal and external events and hazards without common mode failure) using the tools provided by the project for this purpose.	<i>[RQ-0061][RQ-0075]</i>	