

Technical Specifications (In-Cash Procurement)

Manufacturing and assembly of the primary vacuum windows

The purpose of this specification is to provide the technical requirements for specialist work related to manufacturing of the Primary Vacuum Windows Assemblies (55.NW). The work scope is to manufacture the primary vacuum windows (PVW). The work will include the following main activities: Procurement of raw materials of metallic parts and COTS parts Machining and welding of metallic parts Cleaning of the parts Assembly of windows, including the free-issued items provided by IO Factory acceptance ...

SUPPLY

Table of Contents

1	PREAMBLE	3
2	PURPOSE	3
3	ACRONYMS & DEFINITIONS	3
3.1	Acronyms.....	3
3.2	Definitions.....	4
4	APPLICABLE AND REFERENCE DOCUMENTS & CODES AND STANDARDS 4	4
4.1	Applicable documents.....	4
4.2	Reference documents	4
4.3	Applicable Codes and Standards.....	5
5	SCOPE OF WORK	5
5.1	Brief design description of PVM	5
5.2	Window prototypes	7
5.3	Supply items and quantities	8
5.4	Free-issue items	10
6	TECHNICAL REQUIREMENTS	11
6.1	Material requirements	11
6.1.1	Material certificates.....	11
6.1.2	Material traceability	12
6.2	Cutting, machining and forming requirements	12
6.2.1	Cutting & machining operations.....	12
6.2.2	Forming operations	13
6.2.3	Dimensional inspection.....	13
6.3	Welding requirements	13
6.3.1	Welding Procedure Qualification (WPQ).....	15
6.3.2	Qualification of Welders and Operators	15
6.3.3	Workshop Technical Qualification	15
6.3.4	Execution of Production Welds	16
6.3.5	Filler Materials.....	16
6.3.6	Non-Destructive Examination (NDE).....	16
6.3.7	Welding Data Package Documentation	16
6.3.8	Deviations	16
6.4	Ceramic coating requirements	17
6.5	Vacuum and cleanliness requirements.....	17

SUPPLY

6.6	Assembly requirements.....	19
7	IDENTIFICATION AND MARKING	20
8	FACTORY ACCEPTANCE TESTS.....	20
8.1	Thermal cycling	21
8.2	Pressure proof testing.....	21
8.3	He leak testing.....	22
8.4	Outgassing testing.....	22
8.5	Test for sealing between mating flange and WA.....	23
8.6	Test for window prototypes	23
8.7	FAT report	23
9	DELIVERY	24
9.1	Labelling and traceability.....	24
9.2	Preservation, packing and handling	25
9.3	Shipment and delivery	26
10	DELIVERABLES AND SCHEDULE MILESTONES	27
10.1	Schedule for delivery	27
10.2	List of deliverable documentation.....	28
11	QUALITY ASSURANCE REQUIREMENTS.....	29
11.1	Manufacturing and Inspection Plan	29
11.2	Audit and other Inspections	31
11.3	Deviation Request (DR).....	31
11.4	Non-conformity.....	31
12	SAFETY REQUIREMENTS	31
13	CONTRACT MANAGEMENT	33
APPENDIX I – MANUFACTURING AND INSPECTION TEMPLATE FOR MANUFACTURING DATABASE (MDB) (HTTPS://USER.ITER.ORG/?UID=VGDUSJ&VERSION=V2.3)		34
APPENDIX II – DEFINED REQUIREMENTS APPLICABLE TO THIS CONTRACT 35		

SUPPLY

1 Preamble

This Technical Specification is to be read in combination with the General Management Specification for Service and Supply (GM3S) [AD1] that constitutes a full part of the technical requirements.

In case of conflict, the content of the Technical Specification supersedes the content of [AD1].

2 Purpose

The purpose of this specification is to provide the technical requirements for specialist work related to manufacturing of the Primary Vacuum Windows Assemblies (55.NW).

3 Acronyms & Definitions

3.1 Acronyms

The following acronyms are the main one relevant to this document.

Abbreviation	Description
COTS	Commercial off-the-shelf
CRN	Contract Release Note
CRO	Contract Responsible Officer
CV	Clear Viewsize
DR	Deviation Request
DRR	Delivery Readiness Review
ESR	Electroslag remelting
FAT	Factory Acceptance Test
FR	Functional Reference
FSi	Fused Silica
GM3S	General Management Specification for Service and Supply
IO	ITER Organization
IVH	ITER Vacuum Handbook
MIP	Manufacturing Inspection Plan
MRR	Manufacturing Readiness Review
NCR	Non-Conformity Report
NDE	Non-Destructive Examination
PIA	Protection Important Activities
PIC	Protection Important Components
PNI	Part Number of ITER
PPS	Product Procurement Specification
PRO	Procurement Responsible Officer
PVM	Primary Vacuum Window
P-WPS	Preliminary Welding Procedure Specification

SUPPLY

QP	Quality Plan
SAW	Small Aperture Windows
SIC	Safety Important Components
SN	Serial Number
SVS	Service Vacuum System
VAR	Vacuum arc remelting
VQC	Vacuum Quality Class
WPQ	Welding Procedure Qualification
WPS	Welding Procedure Specification
ZnSe	Zinc Selenide
55.NW	Primary Vacuum Windows Assemblies

3.2 Definitions

Contractor: shall mean an economic operator who have signed the Contract in which this document is referenced.

4 Applicable and reference documents & Codes and standards

4.1 Applicable documents

This list contains mandatory documents that the contract shall be compliant with.

- [AD1] General Management Specification for Service and Supply (82MXQK v1.4)
- [AD2] Provisions for Implementation of the Generic Safety Requirements by the External Actors/Interveners (SBSTBM v2.2)
- [AD3] Propagation of the Defined Requirements for Protection Important Components Through the Chain of External Interveners (BG2GYB v3.3)
- [AD4] ITER Policy on Safety, Security and Environment Protection Management (43UJN7 v3.1)
- [AD5] Quality Requirements for IO Performers (22MFG4 v6.3)
- [AD6] Procedure for Management of Nonconformities (22F53X v9.1)
- [AD7] Appendix C3 Product Procurement Specification 316L(N)-IG Forgings for window assemblies (YJWH96 v1.0)
- [AD8] Appendix C5 Product Procurement Specifications X6CrNiTiMoVB25-15-2-Forged-Blocks (YPYLWN v2.1)
- [AD9] Appendix C11 PPS for Ti6Al4V Forgings (4TGFNG v1.1)

4.2 Reference documents

This list contains documents for information:

- [RD1] Appendix 12 Leak Testing (2EYZ5F v1.4)
- [RD2] Appendix 13 Cleaning and Cleanliness (2ELUQH v1.2)
- [RD3] Appendix 4 Accepted Fluids (2ELN8N v1.14)

SUPPLY

- [RD4] ITER Vacuum Handbook Attachment 2 - Cleanliness Requirements Relating to the Assembly of Vacuum Equipment (MBXPP3 v1.7)
- [RD5] ITER Vacuum Handbook (2EZ9UM v2.5)
- [RD6] Appendix 17 Guide to Outgassing Rates and their Measurement (2EXDST v2.2)
- [RD7] ITER Numbering System for Components and Parts (28QDBS v5.1)
- [RD8] Release Note Template (QVEKNQ v3.1)
- [RD9] Package & Packing List Template (XBZLNG v2.2)
- [RD10] Delivery Report Template (WZPYVZ v3.0)
- [RD11] Working Instruction for the Delivery Readiness Review (DRR) (X3NEGB v3.0)

4.3 Applicable Codes and Standards

This is the responsibility of the Contractor to procure the relevant Codes and Standards applicable to that scope of work.

[RQ-0001] The following Standards shall be referred to in this specification:

- RCC-MR-2007 Design and Construction Rules for Mechanical components of nuclear installations
- EN 10204 Metallic products – Types of inspection documents
- EN ISO 3606 Fasteners — Mechanical characteristics of corrosion-resistant stainless steel fasteners

[RQ-0002] All materials and testing standards mentioned in this document shall be considered in their last revision at the time of the sign of the contract.

[RQ-0003] Other equivalent national or international standards and codes may be acceptable with prior written IO approval, provided all criteria are satisfied.

5 Scope of Work

This section defines the specific scope of work, in addition to the contract execution requirement as defined in [AD1].

The work scope is to manufacture the primary vacuum windows (PVW). The work will include the following main activities:

- Procurement of raw materials of metallic parts and COTS parts
- Machining and welding of metallic parts
- Cleaning of the parts
- Assembly of windows, including the free-issued items provided by IO
- Factory acceptance testing
- Packaging and shipping

Final 2D drawings for all the windows will be provided at the Kick-off meeting after contract award. The diamond window (WA017 in Table 1) is still in the final design phase. The final drawing of that window will be provided after the final design is completed, expected in June 2027.

5.1 Brief design description of PVM

The intrinsic function of the PVM is to transmit optic signal or power to diagnose a plasma or machine conditions.

The PVW forms part of the first nuclear safety confinement barrier in ITER. Their integrity is consequently of prime importance in confining the radioactive products inside the vacuum

SUPPLY

vessel. Therefore, window assemblies are classified as Safety Important Component Class 1 (SIC-1). The primary confinement boundary shall be fully ensured during all the normal and accidental conditions.

The PVM also provides the primary vacuum boundary which is required to generate a plasma in the machine. The vacuum class is VQC-1.

The PVS is composed of two main components: mating flange and window assembly. The mating flange is welded to the machine as an intermediate component to install the window assembly to the machine.

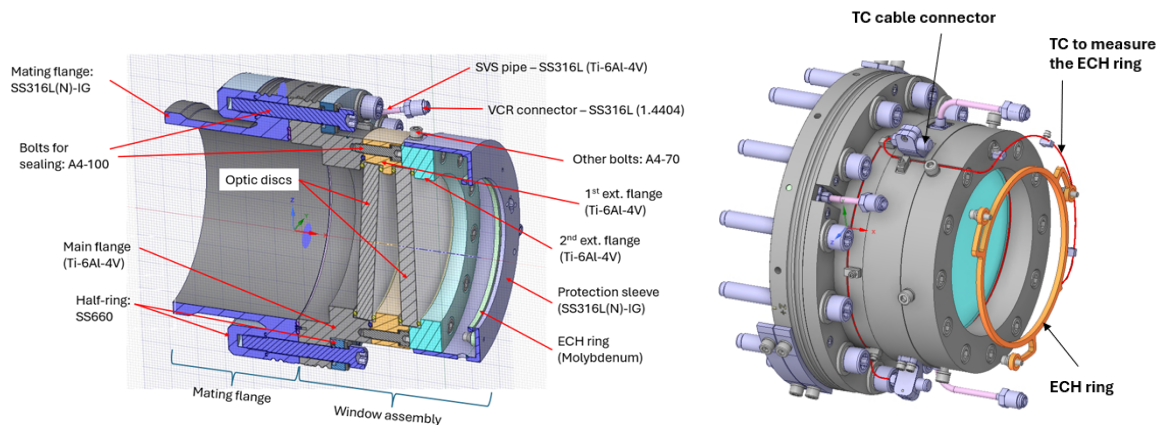

Figure 1 One representative primary vacuum window design

The window assembly consists of the following main parts (see Figure 1 and Figure 2):

- Optic disc(s) made of Fused Silica, Quartz, Sapphire, Zinc Selenide and CVD diamond, depending on the window design variation
- Main flange to be bolted with the mating flange
- Extension flange to be bolted with main flange
- Half rings to press double Helicoflex seal more uniformly
- Double Helicoflex seal (HND229, Technetics product) to provide leak tightness between the mating flange and the main flange
- Single Helicoflex seal Metal gaskets (HNRV200, Technetics product) to provide leak tightness between the flange and the optic disc
- ECH ring made of Molybdenum which are coated with ceramic (Al₂O₃/TiO₂ fixture) on the disc-facing surface
- Thermocouple cable and connector
- Protection sleeve
- SVS pipes and VCR connectors to monitor pressure of the vacuum interspace volume

SUPPLY

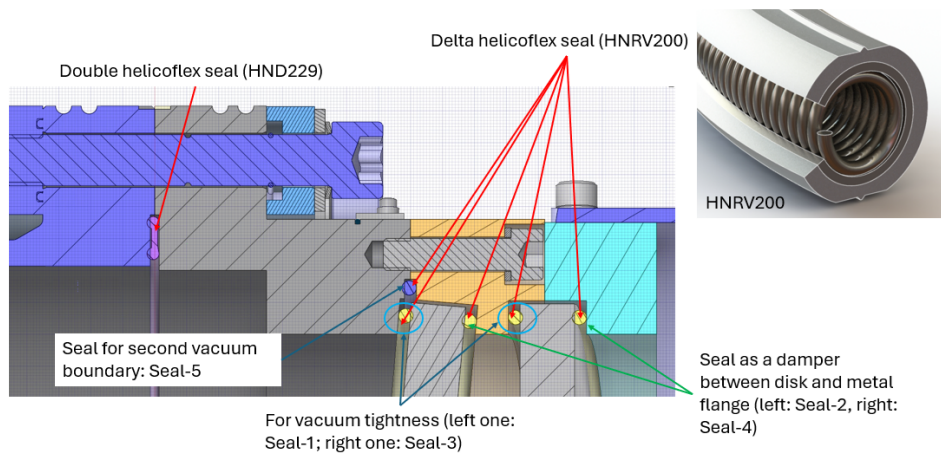

Figure 2 Vacuum sealing of the primary vacuum window

The vacuum-side seal (Seal-2 and Seal-4 in Figure 2) on the optic disk ensures leak tightness, while the seal on the opposite side acts as a damper to stop the brittle disk from making direct contact with the flange. Seal-5 establishes a secondary vacuum boundary by creating a vacuum interspace together with Seal-2, Seal-4, both disks, and the 1st extension flange; this is depicted in Figure 3. Additionally, a small groove has been incorporated into the 2nd extension flange to link the interspace formed by the three seals with the space between the two disks.

Another vacuum interspace is located within the double Helicoflex seal positioned between the mating flange and the main flange. Both of these vacuum interspaces are connected to the ITER service vacuum system (SVS) for leak monitoring purposes, with the SVS pipe welded to the window flange as illustrated in Figure 3.

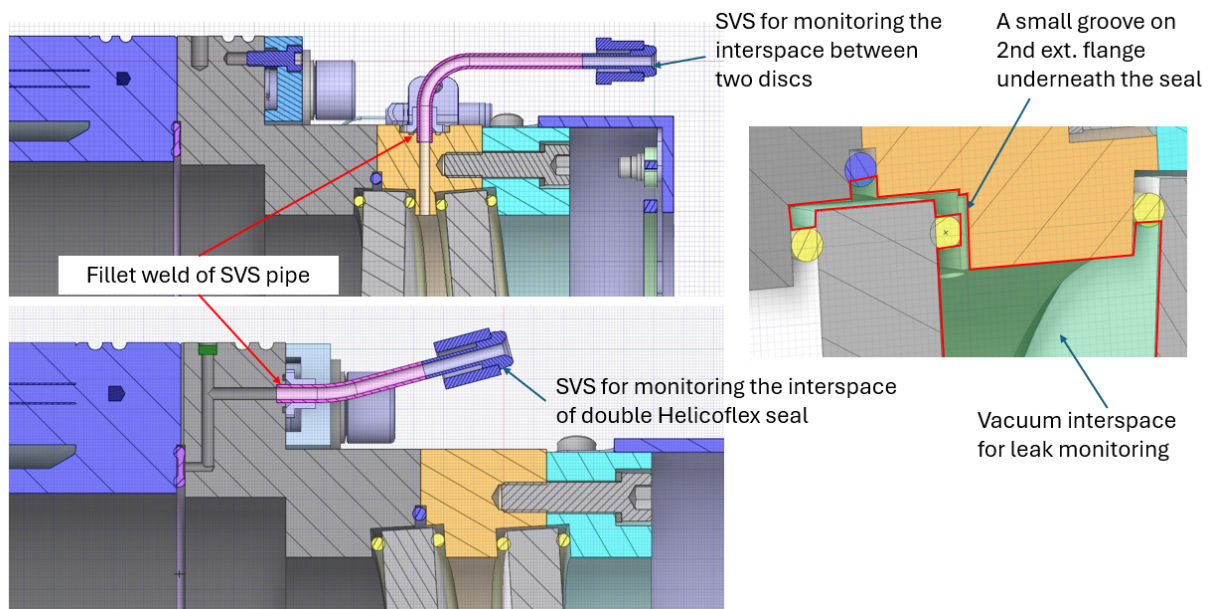

Figure 3 Vacuum interspace volumes for leak monitoring and SVS pipes

5.2 Window prototypes

The window prototypes will serve as test samples for qualification to justify the nuclear safety function of the windows against normal and abnormal conditions. This nuclear safety qualification testing falls outside the scope of the current contract. IO will conduct the tests using the prototypes

SUPPLY

Two distinct window types are required for qualification testing: CV160 Fused Silica and CV130 Quartz windows. Each type must be tested in two configurations, as depicted Figure 4. The testing will begin with five windows in Configuration A, after which certain tests will be conducted on three windows updated to Configuration B from the initial Configuration A group. The Configuration A window comprises a single disk sealed with Helicoflex seals (HNRV200). The metal part is fabricated from Ti grade 5 (Ti6Al4V). An SVS pipe is attached to the vacuum interspace formed by three seals specifically for He leak testing.

The Configuration B window is updated from the Configuration A window by assembling additional parts. These include a support flange, air-side flange, metal seal (O-flex), bolts, and washers, collectively referred to as “Configuration B parts”. The materials of the configuration B parts does not necessarily meet the requirements in Section 6.1; structural elements may utilize SS304 or SS316 stainless steel, and A4-70 bolts are permissible. Regarding the metal seal, other product than O-flex (<https://technetics.com/products/o-flex-metal-seal/>) can be used, provided they ensure the sealing performance required to have 4 bar Helium pressure and they are compatible with the seal groove dimension.

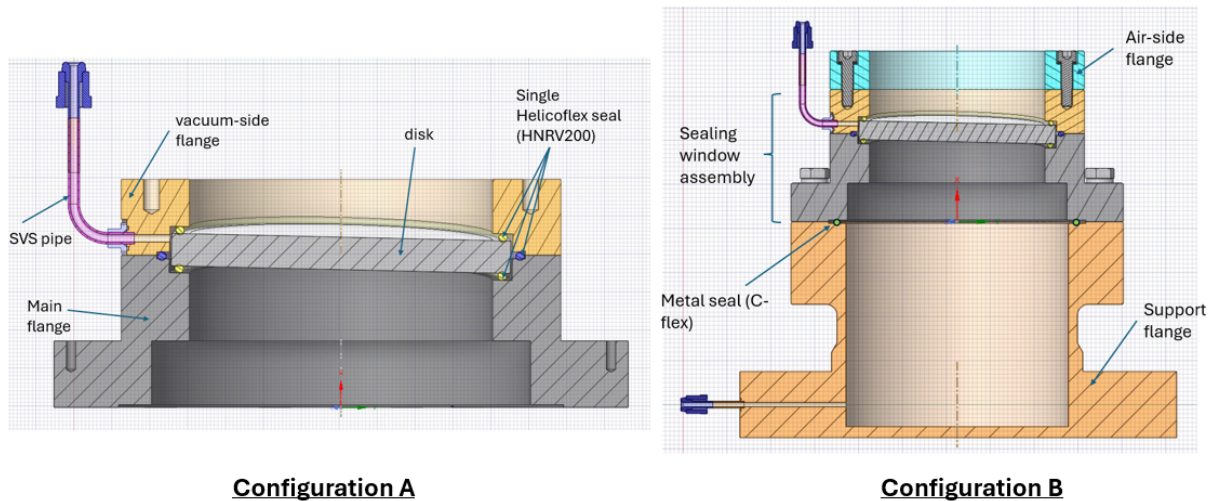

Figure 4 Design of window prototypes

5.3 Supply items and quantities

The Contractor shall manufacture and deliver the following items:

- In-series products of window assemblies listed in Table 1
- In-series products of mating flanges listed in Table 2
- Window prototypes for nuclear qualification listed in Table 3
- Spare parts listed in Table 4

Table 1 – List of in-series products of window assemblies

ID	Window Name	PNI*	Quantities		Remark
			In-series product	spare	
WA001	160_Fsi_B_2Y_-2Y_1_CS		6	1	
WA002	160_Fsi_B_5Y_-5Z_0		5	1	
WA003	160_Fsi_B_5Y_-5Z_0_CS		10	1	
WA004	160_Fsi_B_5Y_-5Z_0_C7_T17.95		3	1	
WA005	160_FSi_B_5Z_-5Z_WELDED FLANGE CS		4	1	

SUPPLY

WA006	160_Fsi_DN250_B_+5Z_-5Z_0_CS		2	1	
WA007	82_Fsi_B_5Y_5Z_0_CS		2	1	
WA008	82_Fsi_B_10Z_-10Z_0		6	1	
WA009	70_Fsi_0_LENGTH_VIEWPORT		14	1	Single disk; non-SIC
WA010	25_Fsi_B_0_0_0_HFSx2		4	1	Four disks Material of window flanges: SS660 & SS316L(N)-IG
WA011	25_Fsi_B_0_0_0_HFS		1	1	Material of window flanges: SS660 & SS316L(N)-IG
WA012	160_Sapph_B_2Y_2Z_0_CS		20	1	
WA013	130_Sapph_B_2Y_2Z_0_CS		2	1	
WA014	130_Qz_B_5Y_5Z_2		2	1	TiO2 coating required on the inner surface of the window flanges
WA015	82_Qz_B_5Y_5Z_0		13	1	
WA016	90_ZnSe_-1Y_5Y_0_CS		7	1	
WA017	103_Diamond_0_0		1	1	Single disk Material of window flanges: SS316L(N)-IG Design is not finalized yet.
Total			102	17	

(*) to be provided after the contract award

Table 2 – List of in-series products of mating flanges

ID	Mating flange	PNI*	Quantities	
			In-series product	Spare
MF001	DN100		13	2
MF002	DN150		11	2
MF003	DN200		29	3
MF004	DN200-Lower		8	1
MF005	DN250		2	1
Total			63	9

(*) to be provided after the contract award

Table 3 – List of window prototypes which will be used for nuclear safety qualification test

ID	Window prototypes		quantity
WP001	CV160 Fused Silica	Window mock-up	5
WP002		Configuration B parts	3
WP003	CV130 Quartz	Window mock-up	5
WP004		Configuration B parts	3

Table 4 - List of spare parts

ID	Item Name	Quantity	PNI*
SP001-a	DN100 threaded half rings and its fixation bolts	8 sets	
SP001-b	DN150 threaded half rings and its fixation bolts	1 sets	
SP001-c	DN200 threaded half rings and its fixation bolts	9 sets	
SP002-a	DN100 Double Helicoflex sealing kit (HND229)	2	
SP002-b	DN150 Double Helicoflex sealing kit (HND229)	2	
SP002-c	DN200 Double Helicoflex sealing kit (HND229)	3	
SP002-d	DN250 Double Helicoflex sealing kit (HND229)	1	

SUPPLY

SP003-a	Double Helicoflex sealing bolts M14 for DN100	20	
SP003-b	Double Helicoflex sealing bolts M16 for DN150 & DN200	50	
SP003-c	Double Helicoflex sealing bolts M16 for DN250	10	

(*) to be provided after the contract award

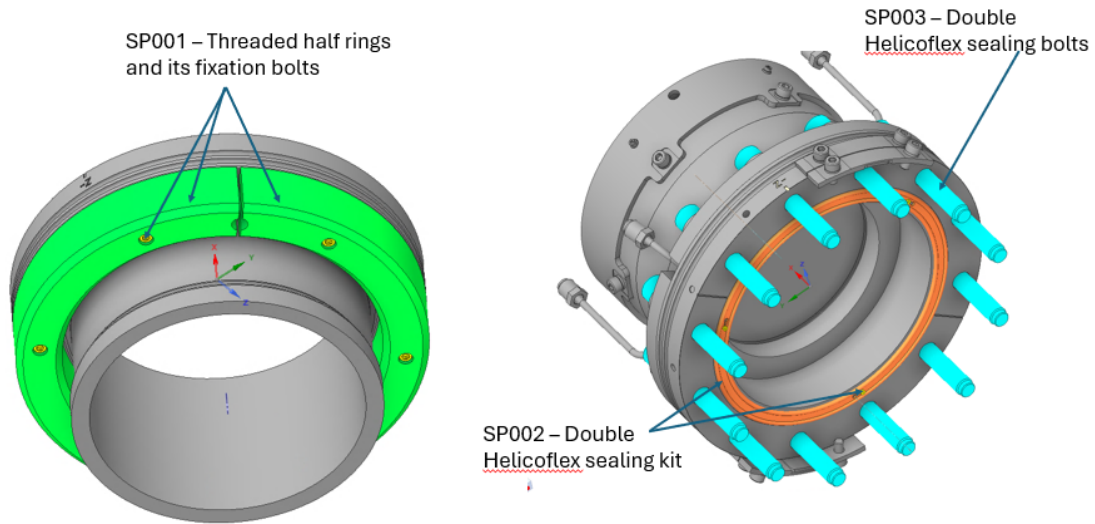

Figure 5 Spare parts listed in Table 4

5.4 Free-issue items

IO will provide to the Contractor the following items required for both the window assemblies and the window prototypes:

- Optic disks
- ECH ring coated with ceramics (Al₂O₃/TiO₂ mixture)
- TC cables and connectors
- Stainless Steel forging materials listed in Table 5

Table 5 - Forging materials to be provided by IO

Item No	Material	Billet size (D: Diameter, L: length)	PNI	Usage	Quantity to be provided by IO	Quantity to be procured by the Contractor*
H1	SS 660 (1.4980)	D205mm x L25mm	I17499320	Unthreaded Half ring-DN100	29	0
H2	SS 660 (1.4980)	D205mm x L45mm	I17499321	Windows W010 & W011 in Table 1	7	0
H2	SS 660 (1.4980)	D205mm x L45mm	I17499321	Threaded Half ring-DN100	29	0
H3	SS 660 (1.4980)	D260mm x L25mm	I17499322	Unthreaded Half ring-DN150	9	4
H4	SS 660 (1.4980)	D260mm x L45mm	I17499323	Threaded Half ring-DN150	9	4
H5	SS 660 (1.4980)	D310mm x L25mm	I17499324	Unthreaded Half ring-DN200	48	7
H6	SS 660 (1.4980)	D310mm x L45mm	I17499325	Threaded Half ring-DN200	48	7
H7	SS 660 (1.4980)	D365mm x L25mm	I17512605	Unthreaded Half ring-DN250	2	0
H8	SS 660 (1.4980)	D365mm x L45mm	I17512606	Threaded Half ring-DN250	2	0
B1	SS316L(N)-IG	D188mm x L748mm	I17512612	Windows W010 & W011 in Table 1	1	0
B2	SS316L(N)-IG	D209mm x L610mm	I17512614	Windows W010 & W011 in Table 1	1	0

SUPPLY

B3	SS316L(N)-IG	D137mm x L400mm	I17512607	Windows W010 & W011 in Table 1	1	0
B4	SS316L(N)-IG	D315mm x L1097mm	I17512624	Windows W017 in Table 1	1	0

(*) These are the SS 660 forgings which cannot be covered with the IO free-issued ones. Therefore, the Contractor should procurement them.

6 Technical requirements

6.1 Material requirements

[RQ-0001] The materials specified in the manufacturing drawings shall be used.

[RQ-0002] SS316L(N)-IG forging materials, which is equivalent to X2CrNiMo17-12-2 controlled nitrogen content austenitic steel described in RCC-MR, shall meet the requirements specified in [AD7].

[RQ-0003] SS660 forging materials, which is equivalent to X6NiCrTiMoVB25-15-2 heat treated structural hardening austenitic stainless steel described in RCC-MR, shall meet the requirements specified in [AD8].

[RQ-0004] Ti6Al4V forging materials shall meet the requirements specified in [AD9].

[RQ-0005] The high strength bolts, A4-100 shall be used for the Helicoflex seal compression. The A4-100 bolts shall meet the requirements specified in EN ISO 3606-1, including the following additional requirements:

- Minimum tensile strength (R_m min.): 1000 MPa
- Stress at 0.2% permanent strain ($R_{p0.2}$ min.): 800 MPa
- Elongation: 0.2~ 0.3d

[RQ-0006] For small quantity of materials or standard off-the-self parts where chemical composition is not available, the chemical composition and impurities (Co, Ta, Nb) content shall be measured so that IO can assess their influence on radiation performance. In case such measurements are impractical the upper estimates for both impurities and mass shall be provided. Deviation Request shall be issued if impurity concentration limits exceed the allowed limits: Co < 0.05%, for Ta < 0.01% and for Nb < 0.01%.

[RQ-0007] Materials (including welds) shall have a relative magnetic permeability less than 1.03.

[RQ-0008] Materials shall be free of Halogenated materials. Halogenated materials, sulphur and phosphorus, and processes involving the use of these materials, shall be avoided. These materials lead to potential for oxidation catalyst poisoning and to metallic corrosion due to acid formation.

[RQ-0009] For helium-containing pipes (SVS pipes) with wall thickness < 2 mm, material must be ESR or VAR, meeting inclusion limits in IVH §5.3.1 [RD5].

[RQ-0010] For the windows of 25_Fsi_B_0_0_0_HFS and 25_Fsi_B_0_0_0_HFSx2 where Fused Silica foams are attached on both sides of the optic discs to reduce microwave reflection, the Fused Silica foams to be used should be Zyafoam 75 (<https://www.vesuvius.com/>) or Fused Silica Foam-50 (<https://www.foundryservice.com/>).

6.1.1 Material certificates

[RQ-0011] All materials delivered under this Purchase Order shall be supplied with an inspection document in accordance with EN 10204:2004. The certificate shall include full traceability to the delivered items via heat number, batch number, and purchase order reference.

[RQ-0012] In case the material manufacturer has carried out a specific assessment for materials and has a proper quality-assurance system, certified by a competent body

SUPPLY

established within the European Community (EU), it is assumed that they can certify conformity with the requirements. Then, the specific assessment of the quality system covers all relevant processes and material properties referred in the material specifications. In this case, inspection certificate 3.1 in accordance with EN 10204:2004 and an inspection report is enough.

[RQ-0013] When the material manufacturer does not have a quality assurance system as described above, inspection certificate type 3.2 in accordance with EN 10204:2004 shall be provided by the material Manufacturer, before agreement with IO. In this case, an independent third-party verification body shall countersign the certificate confirming the validity of tests and inspections.

6.1.2 Material traceability

[RQ-0014] A traceability of all materials shall be established, to ensure that only correct and accepted products and parts are used during manufacturing activities. The traceability shall be guaranteed from the reception stage to the delivery including all intermediate steps during the manufacturing route.

[RQ-0015] The material traceability shall be implemented through dedicated procedures, which shall be subjected to the IO's approval, before starting any manufacturing operations.

[RQ-0016] The methods used for marking shall not result in contamination of the material, significant strain hardening, or sharp discontinuities.

[RQ-0017] The Contractor is required to establish a documented system that unequivocally ensures traceability for components, including optic disks and Helicoflex seals, which cannot be directly marked.

6.2 Cutting, machining and forming requirements

[RQ-0018] Machining operations shall guarantee the functional tolerances and surface finish conditions stated in the drawings in order to ensure a correct service of the component, particularly:

- Compliance with the structural dimensions.
- Compliance with the assembly tolerances.
- Compliance with the machine vacuum.

[RQ-0019] Manufacturing processes shall not introduce contaminants into vacuum-facing surfaces that may be difficult to remove or may degrade vacuum performance.

[RQ-0020] All operations shall comply with the cleanliness rules of IVH Section 24 [RD5] during and after machining, including the prohibition of halogenated solvents for VQC 1 and VQC 3 components.

6.2.1 Cutting & machining operations

[RQ-0021] Requirements in RF 3000 of RCC-MR 2007 shall be applicable.

[RQ-0022] When selected cutting process is plasma arc or gas tungsten arc, at least 1mm depth of the cut edge will be removed by grinding or machining to eliminate the melted and the heat affected region.

[RQ-0023] After cutting the part to the delivery dimensions, the cut edges and surfaces shall be visually examined. They shall be free from strings, tears, grooves, nicks, cracks or other injurious defects.

[RQ-0024] If the results of this visual examination are not conclusive, the surfaces are subjected to liquid penetrant examination in accordance with RMC 5000. The criteria are

SUPPLY

defined in Section 2 of RCC-MR 2017 for parts and products: RM 0325, RM 0335, RM 0345, RM 0355.

- [RQ-0025] Defects detected shall not be repaired by welding. They shall be removed by machining. Once the defect has been removed, the repair area shall always be subjected to magnetic particle (RMC 5000) or liquid penetrant examination (RMC 4000).
- [RQ-0026] After removal or reduction of the defect, the remaining dimensions of the part shall be within the acceptable tolerances.
- [RQ-0027] Machining fluids shall be water-soluble, non-halogenated, phosphorus-free and sulphur-free, with each of halogens, phosphorus, and sulphur ≤ 200 ppm. Machining fluids accepted in ITER are listed in IVH Appendix 4 [RD3]. Any machining fluid not in Appendix 4 requires prior acceptance from the ITER Vacuum RO via the Fluid Acceptance Request Form (ITER_D_48XLVJ).
- [RQ-0028] If using non-recommended fluids, cleaning procedures must ensure full removal of contaminants in accordance with §24 of the IVH [RD5].
- [RQ-0029] The jigs used for the positioning or fastening during the machining operations shall not introduce contaminants into surfaces.
- [RQ-0030] The window assemblies shall have no protrusions or sharp edges able to snag glove clothing or cause surface injury.
- [RQ-0031] Machining tolerances and surface finish specifications outlined in the manufacturing drawings shall be strictly observed. Particular care should be taken with vacuum-sealing surfaces, which necessitate specialised machining processes such as turning and achieving specified surface roughness.
- [RQ-0032] For VQC1 components, the surface roughness must not exceed $6.3 \mu\text{m}$, while for VQC3 components, it should remain below $12.5 \mu\text{m}$.
- [RQ-0033] Where machining creates surface roughness that affects vacuum performance, additional finishing (machining, electropolishing, slurry bead blasting, pickling/passivation) may be required per IVH §8 [RD5].

6.2.2 Forming operations

The forming procedure comprises all the thermo-mechanical operations (thermal cycle, deformation and possible heat treatments after forming) applied to a part or a product in order to obtain a given component.

- [RQ-0034] Applicable requirements to forming processes are described in section RF-4000 of RCC-MR 2007.
- [RQ-0035] The use of any forming procedure shall not result in the properties of the material of a component falling below the minimum required values. After forming, if necessary, heat treatment may be performed to restore the properties of the material such that they comply with the above mentioned requirements.
- [RQ-0036] Forming procedure qualification tests shall be performed in order to demonstrate that the properties obtained, as requested by the product acceptance specification prior to forming, are respected on the finished product. The qualification procedure shall meet the requirements in RF 4120 of RCC-MR 2007.

6.2.3 Dimensional inspection

- [RQ-0037] The Contractor shall measure key dimensions and surface roughness of all flanges related to vacuum sealing.
- [RQ-0038] A high-resolution image of each vacuum sealing surface should be taken to verify proper finish and absence of scratches.
- [RQ-0039] All inspection results must be included in the manufacturing dossier.

SUPPLY

6.3 Welding requirements

The windows include several joints that need to be welded. Figure 6 shows the locations of these welded joints. Each window assembly’s main flange uses a full penetration welded joint (joint 4 in Figure 6) to connect the SVS pipes. Additionally, there are partial fillet welded joints (joints 5 and 6 in Figure 6) between the plug, the SVS pipe, and the main flange.

The diamond window (103_Diamond_0_0), unlike the others, includes extra joints that require full penetration welding at joint 1 to 3 as shown in Figure 6.

The Contractor must follow these welding requirements for any welded joint chosen to improve manufacturing efficiency, such as welding two parts together instead of machining a single component.

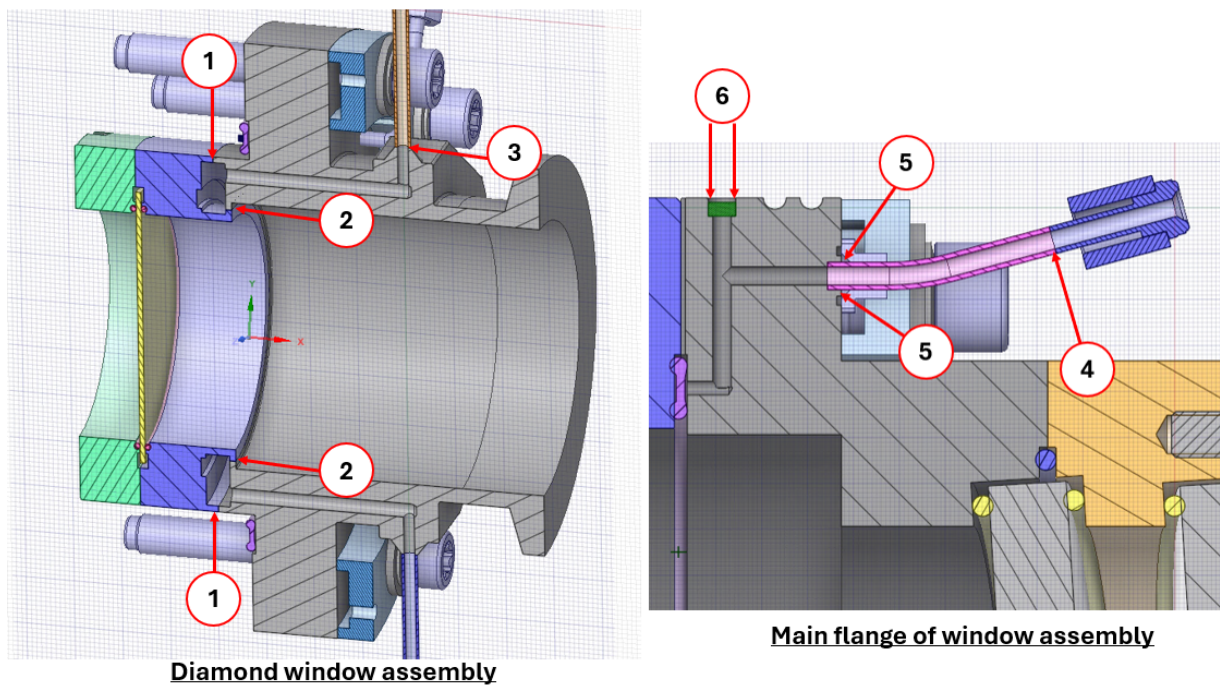

Figure 6 Joints requiring welding: full penetration welding for joint 1 to 4 and fillet welding for joint 5 & 6

The welded window joints follow RCC-MR 2007 Section 1, Subsection C, Class-2 rules for box structures. Welding type II.1 is used for joints 1 to 4, while type VII applies to other partial fillet welds not exposed to mechanical stress. Details on welding types and required NDE are in Figure 7 and Figure 8.

Examples	Definition of types welded joints				
	II.1	butt welding	full penetration	back side inaccessible	gaseous protection with or without insert
	II.2	butt welding	full penetration	back side inaccessible	permanent backing strip
	VII	fillet or T	no penetration	straight edges preparation	single bead

Figure 7 Welded joint types to be applied to the windows as per RCC-MR

SUPPLY

Examinations	Types of welded joints			
	I.1 I.2 I.3 III.1	II.1 III.2	II.2 III.3	IV V VI VII
Volumetric examinations: radiography or ultrasonic examinations Surface examinations: liquid penetrant or magnetic particle examinations				
Volumetric examinations + surface examinations after welding (both sides)	1			
100% Volumetric examination + Surface examination (after penetration pass and front side after welding)	1	1		
Volumetric examinations during welding + surface examinations after welding (one side)	0,85	0,85	0,5	0,5
Volumetric examinations after first pass + surface examinations after welding (one side)	0,7	0,7	0,5	0,5
Surface examinations after welding (one side)	0,5	0,5	0,5	0,5

Figure 8 Examinations required for each welding type of the windows as per RCC-MR

[RQ-0040] All welding activities performed under this Contract shall comply fully with RCC-MR (Edition 2007), Section 4 – Welding, as applicable to Class-2 box-type structures. Compliance includes, without limitation:

- Preliminary verifications, qualifications and acceptances (RS-1110)
- Assessment of material weldability (RS-1200)
- Preheat, interpass, and post-weld heat treatment requirements (RS-1300 series)
- Acceptance and control of filler materials (RS-2000)
- Welding procedure qualification (RS-3000)
- Welder and operator qualification (RS-4000)
- Technical qualification of production workshops (RS-6000)
- Execution and inspection of production welds (RS-7000)
- Non-destructive examinations per weld class (RS-7700)

6.3.1 Welding Procedure Qualification (WPQ)

[RQ-0041] The Contractor shall qualify all welding procedures in accordance with RS-3000, using representative test coupons that reproduce production conditions.

[RQ-0042] The Contractor shall submit all WPQ documentation to IO prior to any welding activity.

[RQ-0043] The Contractor shall ensure that modifications to essential variables require formal requalification.

6.3.2 Qualification of Welders and Operators

[RQ-0044] All personnel performing welding shall be qualified in accordance with RS-4000. Certificates must be valid and available at all times.

6.3.3 Workshop Technical Qualification

[RQ-0045] Welding workshops (Contractor or subcontractor) shall comply with RS-6000, including:

- Adequate welding equipment and controlled environments
- Demonstrated personnel competence
- Documented experience and qualification history

[RQ-0046] A technical qualification report shall be submitted and accepted prior to production.

SUPPLY

6.3.4 Execution of Production Welds

- [RQ-0047] For all vacuum sealing welds, a welding & inspection plan shall be submitted to IO for acceptance prior to manufacturing (per IVH §7.1.2 and Attachment 1 [RD5])
- [RQ-0048] Welding shall follow the approved WPS, with edge preparation, alignment, preheat, interpass temperature, and cleanliness per RS-7300 to RS-7390.
- [RQ-0049] Parts are degreased, rinsed with demineralized water, and dried before assembly; halogenated solvents should be avoided. Only fluids listed in IVH Appendix 4 [RD5] are used.
- [RQ-0050] Welding parameters must be controlled and verified per RS-7432–7434.
- [RQ-0051] Weld pool protection, backing, and surface finishing shall comply with RS-7435–7452.
- [RQ-0052] Unauthorized repairs are prohibited; repair welding must conform to RS-7600 and IVH §7.1.2 and requires IO approval.

6.3.5 Filler Materials

- [RQ-0053] Only filler materials accepted and tested per RS-2000 should be used. Acceptance documentation, batch traceability, and correct storage/conditioning must comply with RS-2100–RS-2260 and RS-7210–7220.

6.3.6 Non-Destructive Examination (NDE)

- [RQ-0054] NDE shall follow RS-7700 for the applicable weld class and weld type.
- [RQ-0055] Liquid penetrant testing (LPT) and magnetic particle testing (MT) should be avoided for vacuum-boundary welds. If LPT cannot be avoided, only the ITER-qualified penetrant should be used with qualified cleaning accepted by the Vacuum RO.
- [RQ-0056] Helium leak testing is required for all vacuum sealing welds according to IVH §7.1.6 and §25 [RD5]. For multi-pass welds classified as VQC 1A, the root pass must be leak-tested before additional passes are made, and then re-tested once the weld is complete and in its final condition.
- [RQ-0057] NDE results must be documented and included in the manufacturing dossier.

6.3.7 Welding Data Package Documentation

- [RQ-0058] The Contractor shall compile a complete RCC-MR-compliant welding data package containing:
- Weld location drawings
 - Catalogue of weld joints and applicable weld types (e.g., Types II.1 and VII)
 - All WPS, P-WPS, and WPQ documentation
 - Welder/operator qualification records
 - Records of NDE, heat treatment, and filler material traceability
 - Production weld data sheets (RS-7470)

6.3.8 Deviations

- [RQ-0059] No deviation from RCC-MR Section 4 shall be implemented without an officially approved Deviation Request. Approval must be obtained prior to performing any work affected by the deviation.

SUPPLY

6.4 Ceramic coating requirements

[RQ-0060] The window variation, 82_FSi_B_2.5Z_-2.5Z_0 shall be coated with TiO₂ on the vacuum surfaces of the main & extension flanges, as indicated in Figure 9.

[RQ-0061] The TiO₂ coating thickness shall be 5 ~ 10 μm.

[RQ-0062] The surface roughness of the coating shall not exceed Ra = 6.3 microns.

[RQ-0063] Ceramic coatings must not form trapped volumes, unvented pores, delaminated layers, or “virtual leak” cavities during application or service.

[RQ-0064] There are coating techniques (plasma spray, thermal spray and chemical vapour deposition) which are well-developed and commercially established for almost all ceramic materials. The contractor shall propose a suitable coating technique and carry out the following tests for 10 coated plates (5 SS316L plates and 5 Ti6Al4V plates) to qualify the coating quality:

- Plate size: 100 mm x 100mm x 5mm
- Coating shall successfully pass 50 thermal cycles (room temperature to 200 °C) (pass criteria: no flaking, blistering or spalling of the coating).
- The coated samples shall pass outgassing tests (pass criteria: Table 5.1 in IVH [RD5]) after 50 thermal cycles
- The coated samples shall pass the adhesion test according to ISO 23114 standard.

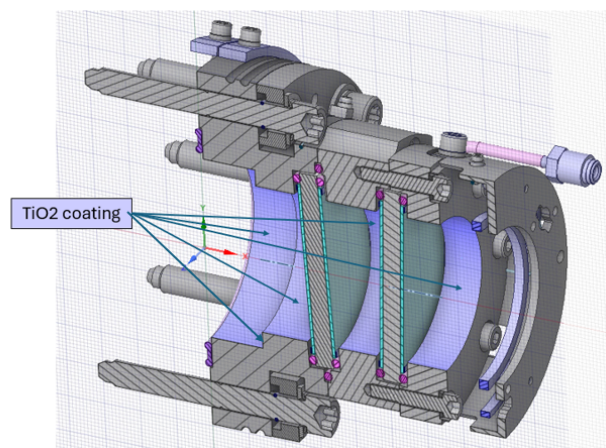

Figure 9 TiO₂ coating area required for 82_FSi_B_2.5Z_-2.5Z_0

6.5 Vacuum and cleanliness requirements

Cleanliness is required during the whole manufacturing process and the preservation of cleanliness is good practice for any component to achieve the necessary vacuum standards and to minimise the time required to recover from any contamination incident.

[RQ-0065] The requirements on cleanliness and surface finish defined in the Section 5, RF 6000 of RCC-MR 2007 are applicable for the manufacture of the window assemblies.

[RQ-0066] All the components shall be subjected to a rigorous cleaning procedure, consistent with the Vacuum Classification of that particular component. A guide to cleaning and handling of components for use on ITER vacuum systems can be found in [RD2].

[RQ-0067] A detailed clean work plan shall be submitted for prior acceptance to the IO before any cleaning operations are undertaken at the Supplier's site. The Supplier is at liberty to propose alternative cleaning procedures to the IO for approval, provided that outgassing results comply with the requirements of this Technical Specification.

SUPPLY

- [RQ-0068] All the components shall be degreased using solvents or alkaline detergents, rinsed with demineralised water, and dried in hot gas or an oven to accepted procedures. The use of halogenated solvents is forbidden at any stage.
- [RQ-0069] Lists of accepted cleaning fluids can be found in [RD3].
- [RQ-0070] Abrasive techniques to clean or to attempt to improve the appearance of the surfaces of vacuum components must be kept to an absolute minimum and are preferably avoided. For all VQC the use of files, harsh abrasives, sand, shot or dry bead blasting, polishing pastes and the like is prohibited under normal circumstances and may not be used without prior agreement.
- [RQ-0071] Grinding on VQC 1 systems is allowed only when essential, using:
- Grinding wheels free of organic components
 - Manufactured in an oil-free, clean environment
 - Fully accepted by the Vacuum RO prior to use
- [RQ-0072] Pickling should always be followed by passivation. This is best carried out chemically, although native oxide layers can reform on exposure to atmosphere. Pickling and passivation must always be followed immediately by an appropriate cleaning process relevant to the VQC of the component.
- [RQ-0073] If pickling is required, final machining of all vacuum-sealing surfaces must be done after pickling and passivation.
- [RQ-0074] After final cleaning, the handling of vacuum equipment shall be strictly controlled to preserve cleanliness. General area cleanliness requirements pertaining to Vacuum Classifications are summarised here. The continuing suitability of any given area used for handling vacuum equipment should be checked on a regular basis by monitoring the airborne particulate count, which should not exceed 5×10^6 particles of size $> 0.5 \mu\text{m}$ per m^3 for VQC 1.
- Cleanliness requirements
 - Segregated clean area
 - Limited access to authorised personnel
 - Authorised equipment operated to approved procedures
 - Management of equipment (e.g. no vacuum pumps or other machinery exhausting into clean area)
 - Personnel
 - Trained personnel
 - Protective hair nets
 - Clean powder free latex or nitrile outer gloves
 - Clean white overalls
 - Overshoes
 - Clean job specific footwear
 - Area Cleanliness
 - Daily cleaning of area including floors and surfaces
 - Sticky mats at area entry
 - Monitoring
 - Daily air quality checks
 - Results stored in component document package
 - Weekly cleanliness test of area with results stored in component document package
- [RQ-0075] A report shall be drawn up for each component or system cleaned. The report shall specify the cleanliness tests performed and the results obtained. This report shall be part of the final manufacturing report of the equipment.

SUPPLY

- [RQ-0076] The outgassing rates shall meet the requirements for VQC-1 components as per [RD5]: Maximum steady state outgassing rate: 1×10^{-7} Pa.m³.s⁻¹.m⁻² for Hydrogen isotopes and 1×10^{-9} Pa.m³.s⁻¹.m⁻² for impurities at outgas temperature 100 °C.
- [RQ-0077] If the compliance of manufacture processes with the outgassing requirements can be demonstrated by conformity to approved clean work and quality plan, there is no need for performing outgassing rate measurements. Otherwise, the outgassing rate measurement shall be carried out as per [RD6].
- [RQ-0078] Direct contact of windows assemblies components with carbon steel or zinc coated slings, chains and the use of tools containing lead, bronze, copper or zinc is forbidden.
- [RQ-0079] Any surface of jigs, fixtures and tools that may come into contact with windows assemblies components shall be constructed from stainless steel or other passive material, which shall not impact the windows assemblies component surface vacuum cleanliness condition or contaminate the stainless steel.
- [RQ-0080] Handling equipment, such as slings, hooks, etc., shall be protected with approved plastic (not PVC), clean wood etc., to avoid direct contact of the stainless steel pieces.
- [RQ-0081] The mandatory requirements relating to cleanliness during assembly of vacuum equipment are detailed in Attachment 2 [RD4].

6.6 Assembly requirements

When installing the disk and Helicoflex seals, each seal shall be centered to maintain a uniform gap with the groove's side wall (see Figure 3). Note that "Seal 1," placed between the two flanges, will have a different axis than the others but must also maintain an even gap.

A jig or fixture may be needed to keep the disk and seals concentric and properly gapped. Once positioned, mount the extension flange using dowel pins to prevent seal movement during assembly. As shown in Figure 3, each seal has delta-shaped edges, and due to the disk's 5° tilt, the seal is inclined from the horizontal. Mounting the extension flange vertically can cause the seal to shift sideways during compression. The tilting angle varies, depending on the window type.

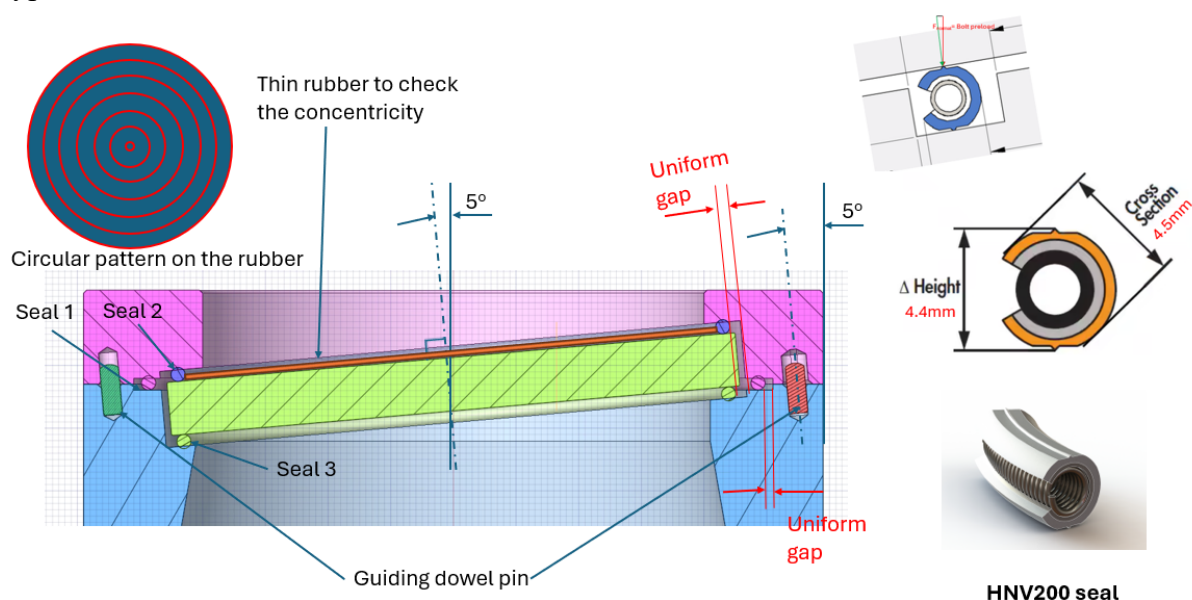

Figure 10 Cross-section of the window showing the dowel pins to guide the extension tube, the delta-shaped seal (HNV200), and a tool to check the concentricity of the disk after assembly.

After correctly positioning the extension flange, the bolts are inserted and initially tightened by hand. Subsequently, using a calibrated torque wrench, the bolts have to be tightened in a

SUPPLY

criss-cross (star) pattern, e.g. following the numbered sequence shown in Figure 11. Torque needs to be applied in incremental steps (2Nm per each step), repeating the sequence in reverse order at each step until the final torque is reached.

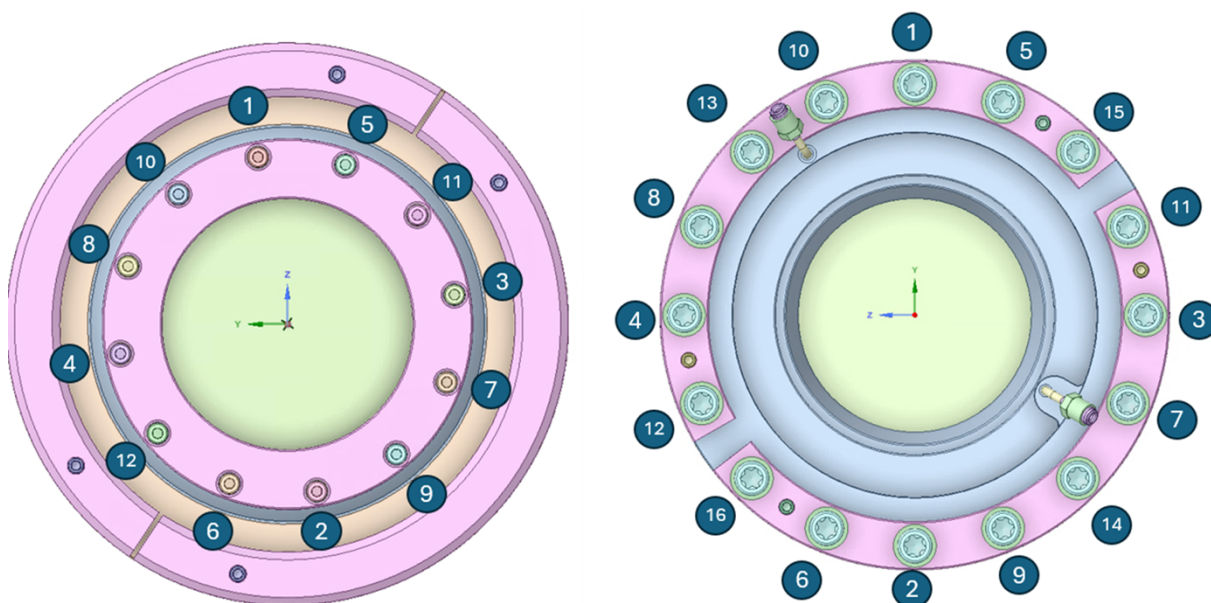

Figure 11 Bolt tightening sequence for 160_Fsi_DN250_B_+5Z_-5Z_0_CS

For the main vacuum flange, the bolt tightening sequence is the same. The only difference is the total number of bolts and the bolt torque. The required bolt torque should be achieved by increasing 12Nm for each step.

[RQ-0082] Each seal must be precisely centered to ensure a consistent gap with the groove's side wall.

[RQ-0083] The extension flange should be installed using dowel pins to prevent seal movement during assembly.

[RQ-0084] For Helicoflex seals, bolts should be tightened using a criss-cross (star) pattern, gradually increasing the tightening torque until achieving the specified value indicated in the 2D drawing, as explained above.

7 Identification and Marking

[RQ-0085] Upon completion of assembly, the window assembly shall be permanently and indelibly marked in a visible location, and the mating flange shall also be clearly identified in an appropriately conspicuous area. See Figure 14.

[RQ-0086] All labelling shall follow the IO official numbering system according to the document "ITER Numbering System for Components and Parts" [RD7].

ECH sensors, cables, connectors, and optic disks will be pre-labelled by IO before delivery to the Contractor.

8 Factory acceptance tests

After the completion of all manufacturing processes, each window assembly should undergo the following tests before delivery to the ITER site.

SUPPLY

- 1st test: thermal cycling
- 2nd test : Pressure proof testing
- 3rd test : Helium leak testing

After three thermal cycles, the Contractor shall perform pressure proof testing followed by Helium leak testing.

Outgassing tests performed on the 1st of a kind variation form also part of the final acceptance testing, unless the compliance of the window assembly manufacture with the outgassing requirements specified in [RD5] can be demonstrated by conformity to a clean work and quality plan.

The FAT needs to be performed after the assembly for the glass sealing is completed and before the non-vacuum parts (protection sleeve, ECH sensors, cable/connectors, half-rings, etc) are installed, as shown in Figure 12.

[RQ-0087] In accordance with the requirements outlined in the subsequent sub-sections, the Contractor is required to develop a comprehensive test procedure. This procedure must be submitted for approval by the IO prior to the commencement of the factory acceptance test.

8.1 Thermal cycling

[RQ-0088] Each window assembly shall be subject to three consecutive thermal cycles:

- Increase the WA temperature from room temperature up to 200°C (-0, +10°C), maintaining a ramp-up rate of less than 10°C/h.
- The duration required to reach 200°C from room temperature must not exceed 100 hours.
- The WA shall be held at 200°C for a minimum of 24 hours.
- Subsequently, reduce the WA temperature down to room temperature at a ramp-down rate of < 10°C/h.

[RQ-0089] The Contractor shall monitor, control and record the WA temperature during thermal cycling.

[RQ-0090] The thermal cycling must not reduce the cleanliness of the WA.

8.2 Pressure proof testing

The objective of the pressure proof testing is to check that the glass/ceramic discs of the window assemblies have adequate mechanical properties before being placed into service. The proof pressure is defined so that the presence of a crack in either discs greater than the critical crack size would lead to the failure of the disc during the test. In contrary an assembly having succeeded the test is proven to be free from crack greater than the critical crack size.

[RQ-0091] Each window assembly must be proof-tested at a 2 bar pressure differential after bolting the extension flanges to seal the glass.

[RQ-0092] A 3 bar (0/+0.3bar) pressure shall be applied for 1 minute +/- 5 seconds to the vacuum interspace between the disks via the SVS pipe (see Figure 12). The pressure differential should be gradually increased, taking more than 10 seconds but less than 60 seconds to reach full pressure.

[RQ-0093] During the execution of the tests, the pressures in the vacuum interspace shall be recorded as a function of the time. One record per second is required.

[RQ-0094] The pressure proof testing facility shall be commissioned before starting any test on actual window assemblies. A commissioning report shall be issued by the supplier for IO approval.

SUPPLY

[RQ-0095] During the commissioning of the testing facility, reference pressure gauges shall be implemented to confirm accuracy of the pressure measurements, expected less than $\pm 1\%$ of the pressure measurement range (0 ~10 bar), i.e. less than 0.1 bar.

[RQ-0096] The gas used to pressurize the volume shall keep the cleanliness of the window assembly under tests.

[RQ-0097] The pressure proof test has to be performed at ambient temperature ($20^{\circ}\text{C} \pm 5^{\circ}\text{C}$).

[RQ-0098] A visual inspection must be carried out after testing. The optic disk will be considered acceptable if no defects are found.

8.3 He leak testing

[RQ-0099] He Leak testing shall be carried out by suitably trained and experienced personnel. The contractor is required to get prior acceptance for the leak test method from IO. Guidance can be found in [RD1].

[RQ-0100] To be accepted, the leak test must demonstrate compliance with the following leak rate criteria:

- VQC1 vacuum boundary: leak rate $\leq 1 \times 10^{-10} \text{ Pa}\cdot\text{m}^3\cdot\text{s}^{-1}$ (air equivalent)
- VQC3 vacuum boundary: leak rate $\leq 1 \times 10^{-9} \text{ Pa}\cdot\text{m}^3\cdot\text{s}^{-1}$ (air equivalent)

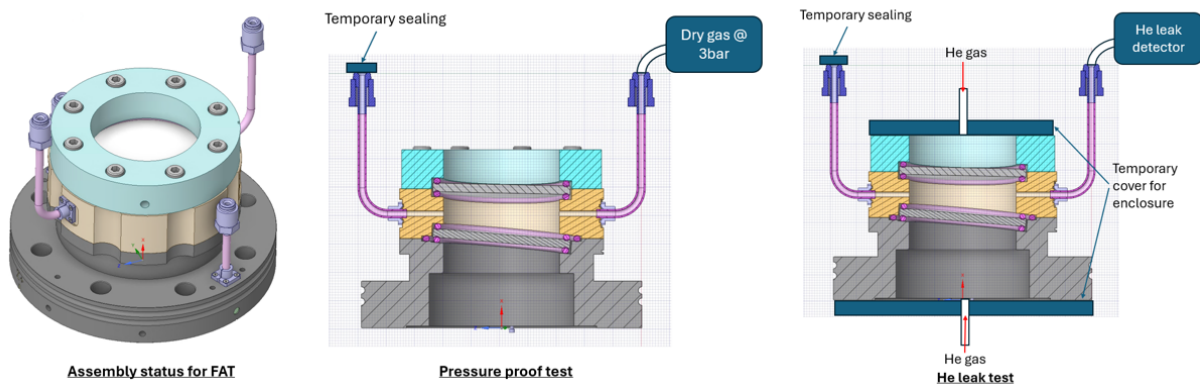

Figure 12 Test configuration for FAT of window assemblies

8.4 Outgassing testing

Outgassing test on the initial WA product is part of the final acceptance tests, unless the window assembly manufacturing process is demonstrated to comply with the outgassing requirements outlined in IVH [RD5] through a documented clean work procedure and quality plan.

This test verifies that any gases dissolved, trapped, or absorbed in the window assembly materials are sufficiently removed to meet the vacuum performance requirements.

The Contractor can conduct the outgassing test on any window assembly variation manufactured under the approved procedures.

[RQ-0101] The Contractor shall carry out the outgassing test as per the procedure approved by IO. Guideline for the outgassing test is given in [RD6].

[RQ-0102] The following acceptance criteria of outgassing rate shall be satisfied at steady state:

- For VQC1 components: below $10^{-7} \text{ Pa m}^3\cdot\text{s}^{-1}\cdot\text{m}^{-2}$ for hydrogen isotopes and $10^{-9} \text{ Pa m}^3\cdot\text{s}^{-1}\cdot\text{m}^{-2}$ for other impurities
- For VQC3 components: below $10^{-7} \text{ Pa m}^3\cdot\text{s}^{-1}\cdot\text{m}^{-2}$

SUPPLY

8.5 Test for sealing between mating flange and WA

For the double Helicoflex sealing between the mating flange and the window assembly, He leak test will be carried out for only one window per each mating flange size (DN100, DN150, DN200 and DN250) since the Helicoflex seal is single-use and testing all windows is not cost-effective. If the sealing surface is machined as per the surface finish and roughness requirements stipulated in the drawings, it can be assumed that the required leak tightness is achieved. This assumption can be verified with this He leak test.

Figure 13 shows how the window is set up for this test. During the procedure, all Helicoflex seals are tightly compressed with bolts, while components like protection sleeves, ECH sensors, cables, and connectors are not included.

For the four selected windows, the tests outlined in Section 8.1, 8.2 & 8.3 can be combined together with this test, i.e., following thermal cycling and pressure proof testing, the He leak test must include both glass and mating flange seals.

[RQ-0103] The He leak test shall be performed for each one of the following window product after thermal cycling and pressure proof testing, as per the requirements specified in Section 8.1, 8.2 & 8.3.

- 82_Fsi_B_5Y_5Z_0_CS + mating flange DN100
- 130_Qz_B_5Y_5Z_2 + mating flange DN150
- 160_Fsi_B_5Y_-5Z_0_CS + mating flange DN200
- 160_Fsi_DN250_B_+5Z_-5Z_0_CS + mating flange DN250

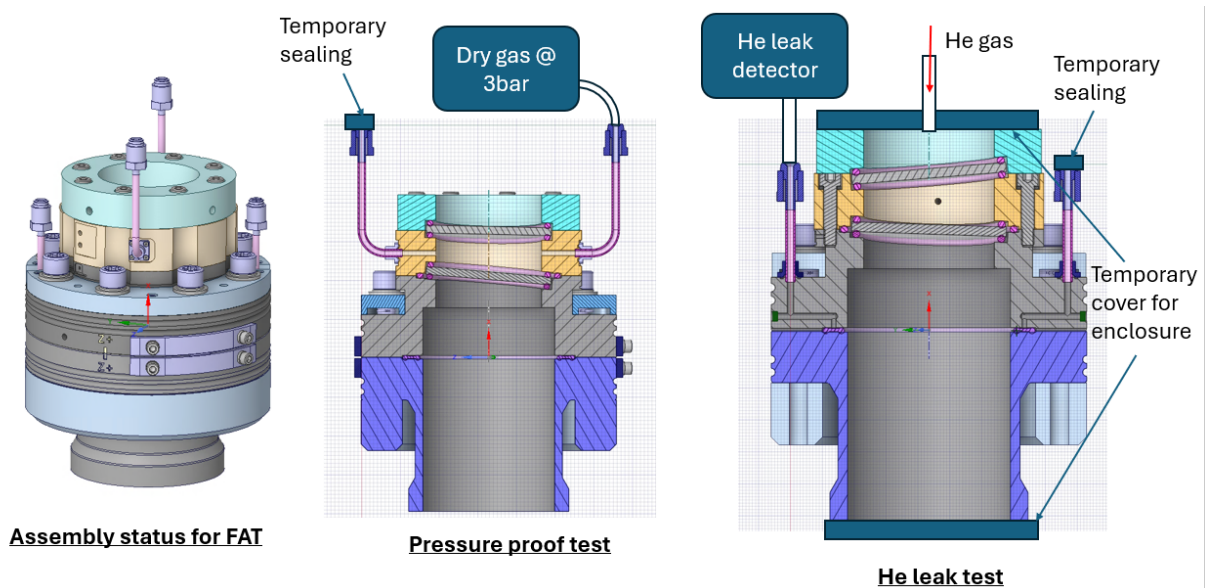

Figure 13 Test configuration for FAT of the double Helicoflex sealing between the mating flange and the window assembly

8.6 Test for window prototypes

[RQ-0104] Regarding the window prototypes listed in Table 3, only He leak testing in Section 8.3 is required.

8.7 FAT report

[RQ-0105] At a minimum, the FAT report must include the following information:

- Administrative information
 - Reference to the approved test procedure

SUPPLY

- Identification of items tested: WA type, reference number (FR, PNI, serial number)
- Identification of organizations: manufacturer name & address, testing laboratory (if external), inspection agency (if applicable)
- Purchase order /contract number
- Testing Equipment and Calibration Status
 - List of instruments used
 - Calibration certificates
 - Measurement uncertainty declarations where applicable
- Test Conditions and Environmental Records
 - Ambient temperature
 - Humidity
- Thermal Cycling Test Results
 - Temperature vs. time plots
 - Any anomalies noted (discoloration, deformation, contamination)
- Pressure Proof Test Results
 - Pressurizing medium
 - Pressure-time curve
 - Post-test visual inspection report
- Helium Leak Test Results
 - Leak detector data logs: output data of all global leak tests, data from standard leak calibration, data from response time determination, date and time of each test, start and finish times of He application to the component
 - He concentration of the enclosure volume
 - Test results: pass/fail, leak rates, leak locations and corrective actions if applicable
- Outgassing test (if applicable)
 - Baking temperature
 - Outgassing curves (rate vs. time)
 - Calculation method (per [RD6] guideline)
- Nonconformities and Deviations: description, root cause (if known), corrective measures, NCR/DR reference (if applicable)
- Declaration of Conformity
 - Statement that all tests comply with technical specification
 - Signature of responsible test engineer
 - Signature of QA representative

9 Delivery

The Supplier shall deliver all the components listed in Table 1, Table 2, Table 3, and Table 4 as per the delivery schedule specified in section 10.1.

[RQ-0106] The Contractor must create a labelling and packing plan and obtain approval from IO before beginning packaging.

9.1 Labelling and traceability

[RQ-0107] All labelling shall follow the IO official numbering system according to the document “ITER Numbering System for Components and Parts” [RD7]. A detailed ‘IO component identification standard’ together with printed label templates and RFID tagging standards will be provided by IO.

SUPPLY

[RQ-0108] The in-series window products have to be packed as shown in Figure 14. An identifier should be added to the label of each pack in the following way:

- Package for each window assembly: FR
 - Sub-package for Item (window body): PNI +SN
 - Sub-package for Kit 1 (rectangular guiding pin plates): PNI
 - Sub-package for Kit 2 (rectangular guiding hole plate): PNI
 - Sub-package for Kit 3 (bolts for rectangular guiding plates): PNI
 - Sub-package for Kit 4 (washers for rectangular guiding plates): PNI
- Package for each mating flange: FR + PNI + SN

[RQ-0109] The PNI and SN must be marked directly on the surface of both the window assembly and the mating flange, as illustrated in Figure 14.

[RQ-0110] Each package (whether a plastic bag or rigid box) should also have a label with the necessary identifiers (FR, PNI, SN) attached.

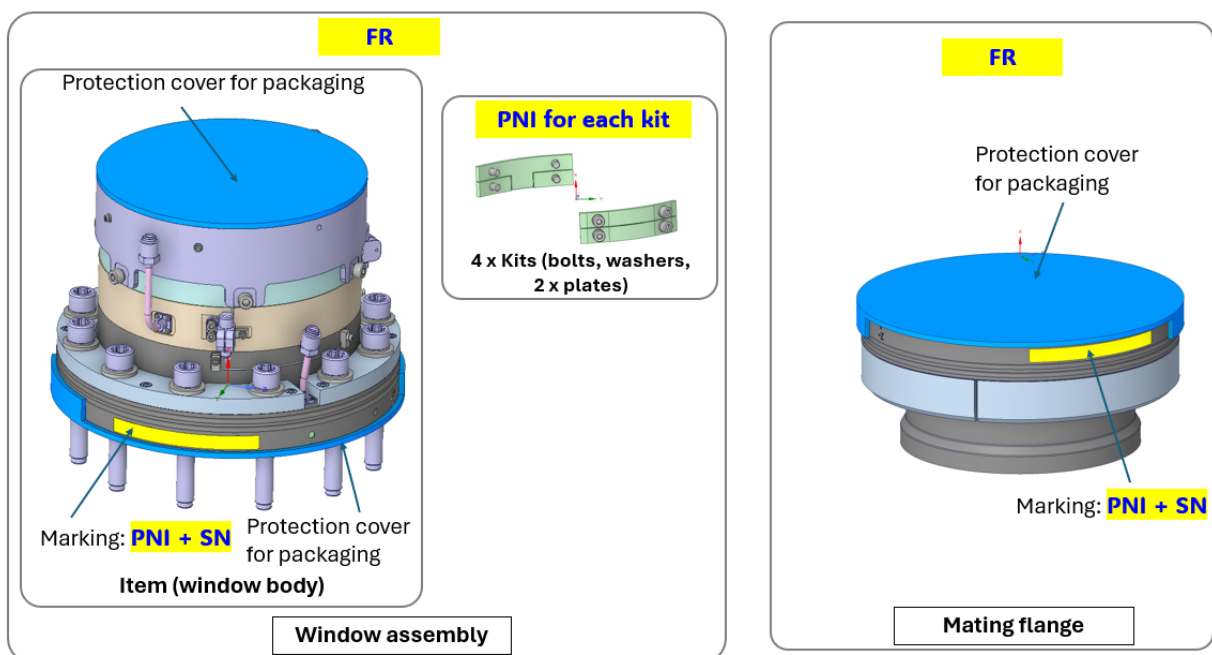

Figure 14 Scheme for window packing and their identifiers

9.2 Preservation, packing and handling

[RQ-0111] Each window assembly shall be packed in the following way, as presented in Figure 14:

- The window body in Figure 14 to be packed in a hermetically sealed plastic bag
- Each kit of the window assembly to be packed in a plastic bag
- The packed window body and all the packed kits to be packed in a rigid box
- The mating flange to be packed in a hermetically sealed plastic bag and then the packed mating flange to be packed in a rigid box.

[RQ-0112] The Contractor shall design protection covers in Figure 14 and any other jigs necessary for proper packing, handling and storage.

[RQ-0113] Where practical, vacuum components shall be entirely enclosed in heat sealed polyethylene for shipping. The polyethylene enclosure shall be purged and backfilled with dry air (<4000 ppm H₂O). Where this is not practical, alternative conditions shall be accepted by the vacuum RO.

SUPPLY

[RQ-0114] The Contractor is required to package the rigid box within a wooden crate for shipment, ensuring that an itemized list is included. The window assembly and the mating flange are to be packed separately.

[RQ-0115] An accelerometer must be attached to each crate to monitor compliance with the movement limit (< 3g in any direction).

[RQ-0116] Components shall be packed with adequate protection from thermal or mechanical stresses which may adversely affect the component. All packing shall be marked externally with the vacuum and SIC classification of the component. Handling instructions shall also be clearly marked on the outside of the packaging. All such marking shall be in English and French.

[RQ-0117] To prevent damage and possible contamination during transit, the packaging of components shall be done as soon as possible after acceptance testing and final cleaning at the supplier's premises. Cleaning and packaging operations may be witnessed by ITER.

[RQ-0118] For the window prototypes, FR and PNI are not assigned so they need to be identified with component name (e.g., CV160 Fused Silica Configuration A) and serial number. Configuration B parts should be packaged separately from configuration A. Hardware such as bolts, washers, and the metal seal must also be packed separately, but included with configuration B. Please refer to Figure 15 for additional guidance.

[RQ-0119] Prior to delivery to ITER site, the components shall be stored in clean and dry conditions, protected from normal hazards.

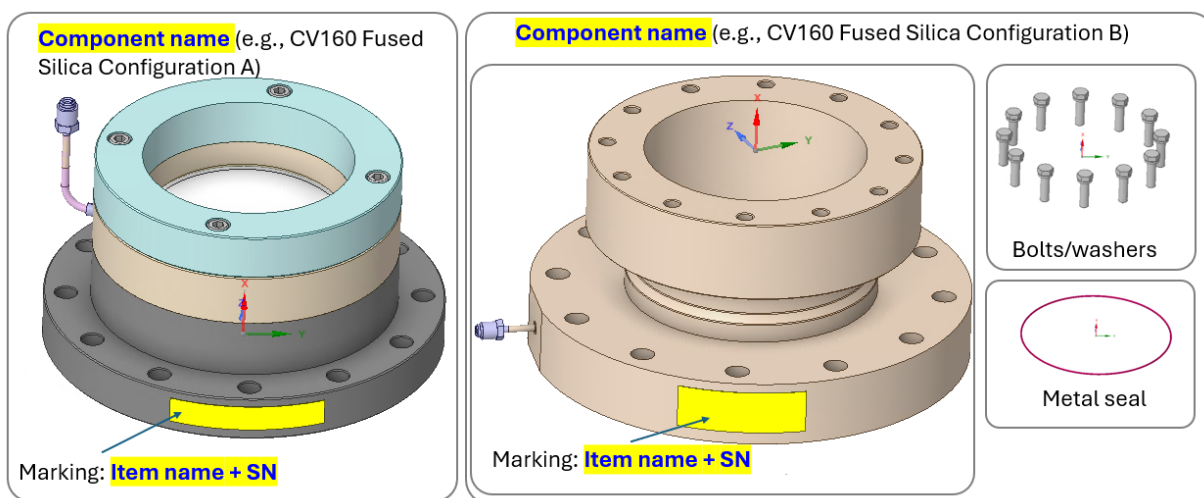

Figure 15 Scheme for packing and their identifiers of window prototypes

9.3 Shipment and delivery

[RQ-0120] Each shipment shall be accompanied by a Contract Release Note (CRN) prepared by the Contractor, using the Release Note template [RD8].

[RQ-0121] The CRN shall

- Certify that the product meets the Contract requirements
- List the documents and records constituting the manufacturing dossier and their status
- List any outstanding obligations

[RQ-0122] The following documents and records should be included in the CRN as minimum:

- Management Documents:

SUPPLY

- Quality plan
- List of contractors/subcontractors
- Packing list using the template provided by IO [RD9]
- Raw Materials
 - Material certificates
- Manufacturing Dossier
 - Manufacturing and Inspection Plan
 - Documentation for welding procedure and NDT (WPS, PQR, welder qualifications, NDT report, etc.)
 - Cleaning work plan
 - Final factory acceptance test report
 - Deviation and Non-conformity reports
 - MIPs which are completed with records during manufacturing

[RQ-0123] The CRN shall be signed by a representative of the IO and the Contractor. The signature by the IO of the CRN prior to shipment represents a Hold Point (HP).

[RQ-0124] The Contractor shall provide a delivery report [RD10] and a packing list for DRR (Delivery Readiness Review). The purpose of the DRR is to review and validate Contractor's documents [RD11]. No shipment is allowed without a successful DRR.

10 Deliverables and Schedule Milestones

10.1 Schedule for delivery

Referring to tables in section 5.3 (Table 1, Table 2, Table 3, Table 4), in the following table it is reported the Delivery Schedule expected from IO. The maximum expected duration from the contract signature to the supply of the scope of work is [30] months.

Table 6 - expected detailed schedule with associated deliverables

Schedule Milestones	Description	Related deliverables from Table 7	Is Contract Gate? (Y/N)	Expected Timing ¹ (T0+x) *
#1	Work plan and schedule	P#01 P#02 P#03	N	1
#2	MRR-1 for window prototypes	P#04 P#05 P#06	Y	3
#3	DRR-1 and delivery of all window prototypes listed in Table 3	P#07 P#08	Y	6
#4	MRR-2 for mating flanges	P#04 P#05 P#06	Y	8
#5	DRR-2 and delivery of all mating flanges listed in Table 2	P#07 P#08	Y	20
#6	MRR-3 for window assemblies	P#04 P#05 P#06	Y	10

¹ This timing is only tentative for the moment and could be discussed with the contractor according to its manufacturing capabilities prior the starting of this Contract.

SUPPLY

11 Quality Assurance requirements

The Quality class under this contract is QC1.

[RQ-0125] The Contractor shall have an ISO 9001 certified quality system or alternatively a QA Program approved by IO QARO. In addition, the quality management system shall comply with the IO quality requirements as per [AD6].

[RQ-0126] The Contractor shall produce its own Quality Plan (QP) and QP of the subcontractors in accordance with [AD6] and submit them to the IO RO for acceptance within 1 month after the KOM.

[RQ-0127] Documentation developed as the result of this Contract shall be retained by the Supplier for a minimum of 5 years and then may be discarded at the direction of the IO.

[RQ-0128] The Contractor shall transmit their document via the IDM system using the IDM Exchange folder area, with the exception of and when applicable:

- Computer-Aided Design (CAD) files that have to be transmitted in the CAD database (SMDD).
- Non-Conformity Report (NCR) that have to be transmitted via the NCR Database.

11.1 Manufacturing and Inspection Plan

[RQ-0129] Manufacturing and Inspection plans (MIP) shall be used to monitor quality control and acceptance tests during the implementation of the Contract. The rights of the IO listed above shall apply in relation to any subcontractor and in this case the IO will operate through the Contractor. The overseeing of the quality control operation by the IO shall not release the Contractor from his responsibility in meeting any aspect of their obligations under the Contract.

[RQ-0130] The Contractor shall ensure a close follow-up across their supply-chain, which include their activities as well as their Subcontractors', and Suppliers' when it comes to PIC/PIA. As such, the Contractor shall ensure propagation of requirements to its Subcontractors and Suppliers as needed and define in their QA plan how the Contractor manage the follow-up and inspection of their supply-chain.

[RQ-0131] This monitoring shall include control points at critical steps in the Contractors' plans. The control points shall be integrated into the agreed schedule. MIP shall clearly highlight the PIAs and PICs.

[RQ-0132] Drawings, standards, specification, instructions, codes and the Contractor quality control procedures which are applicable to the inspection plan shall be clearly identified as to their source, title, number and applicable revision. All drawings, codes and standards referred in the test plan shall be listed in a separate document section. Reference to a standard and/or code shall indicate the pertinent chapter, section clause or paragraph and edition. Flow diagrams or a separate sequential plan that would enable to clearly define some completion stages, if needed. The applicable procedures shall be mentioned for each inspection and testing phase.

SUPPLY

[RQ-0133] The Contractor shall not commence manufacturing activities prior to confirmation of inspection plan's acceptance by the CRO.

[RQ-0134] Any change to an approved MIP shall be resubmitted to the CRO for acceptance.

[RQ-0135] MIP shall list all operations that are critical from a quality point of view. As such, QARO and CRO reserve the rights to request for MIP revision if any activity becomes critical and is not listed in MIP. Typical Manufacturing Inspection Plan is available in Appendix I.

[RQ-0136] Several control points shall identify in each MIP:

- **HP (Hold Point)** identifies an operation that must be formally sign-off by an IO or third party representative mandated by the IO before the work continues beyond this point. The work must not continue until the release delivered by IO or/and the Third Party. Where physical witnessing is required for a HP, this must be clearly indicated in the inspection plan for the associated task. IO or Third Party may add a Hold Point to a specific activity at any time during implementation of the work by the Contractor.
- **NP (Notification Point)** identifies an operation/task that must be notified to the IO or a Third Party. IO or Third Party are invited to attend to the operation/task but if they don't attend at the notified time, the work can be proceeded by the Contractor.
- **RP (Registration Point)** identifies an activity where the IO or Third Party not invited to attend but they need to be informed immediately of the results by the Contractor. The information is delivered by the relevant record signed-off by the Contractor. The work can continue when the record has been delivered to IO.
- **W (Witness):** identifies an operation that must be witnessed.
- **S1 (Surveillance 1):** identifies an operation that requires 100% inspection.
- **S2 (Surveillance 2):** identifies an operation that requires random inspection or spot checks.
- **R (Review)** identifies a document that must be reviewed by the IO or Third Party.

[RQ-0137] IO reserve the right to waive partially or in full their attendance and will inform Contractor via their response to Contractor notification for inspection.

[RQ-0138] For Hold Points, Notification Points and Witness Points the Contractor shall notify the inspection body representative at least 2 weeks prior to the implementation of the activity for any operation. When inspection requires overseas travel of IO representative, this notice is extended to 3 weeks. Upon mutual agreement between the different stakeholders, the notification period may be reduced.

[RQ-0139] When an inspection is organised at the Contractor or subcontractor premises, access shall be granted by the Contractor to the premises for IO representative and/or any third party inspectors as designated by ITER Organization.

[RQ-0140] IO attendance to an inspection and/or test phase shall not relieve the Contractor from their own obligation to perform the control and the Contractor Quality Control team is responsible for endorsing the outcome of the inspection and/or test phase.

SUPPLY

[RQ-0141] The Contractor shall provide timely and regular reporting on inspection progress. If the Contractor has an online tracking system for their inspection, they shall grant access to IO representative for the test plan follow-up under the Contract. Alternatively, the Contractor shall use IO systems, such as but not limited to: manufacturing database (MDB). In case the Parties agree not to use any system for inspection follow-up, the Contractor shall at least provide the latest test plan dully marked-up as an appendix to their monthly report.

[RQ-0142] Particular attention shall be paid to the traceability of all materials:

- Material origin; date of manufacturing
- Material manufacturing process identification
- Heat number of raw materials
- Tests and inspections records

11.2 Audit and other Inspections

If and when required, audits, inspections (further to the one defined in the MIP or ITP) and surveillance visits of Contractor's activities or its sub-contractors may be organized by either IO, regulatory bodies or the French Nuclear Authority without prior warning.

The Contractor shall grant access rights to IO, and regulatory body representatives to their offices, facilities and records.

The Contractor shall flow this requirement down to their subcontractors to allow IO, regulatory bodies and the French Nuclear Authority to also perform the above actions in their premises.

11.3 Deviation Request (DR)

The Contractor may raise a Deviation Request to ask for the authorization to depart from a contractual requirement. Deviation Requests shall be approved by IO before implementation of the related activity(ies) (e.g. manufacture of the item).

Deviation Requests shall be managed using IDM IT system (unless agreed differently) from initial submission to closure as defined in section 6.2.2 of [AD1].

11.4 Non-conformity

Any item, process or work that does not fulfil its specified requirements shall be identified and segregated as being nonconforming. Each nonconforming item or work shall be prominently tagged, or uniquely identified and, when practical, segregated to prevent its use. Contractor shall comply with [AD6].

12 Safety requirements

ITER is a Nuclear Facility identified in France by the number-*INB-174* ("Installation Nucléaire de Base").

The components under this contract are Protection Important Components (PIC) and SIC-1 (Safety Important Component) and also include Protection Important Activities for manufacturing and inspection.

SUPPLY

A **Protection Important Component (“PIC”)**, as per INB Order Article 1.3, is defined as “a component which is important for protecting the interests mentioned under Article L. 593-1 of the Environmental Code (nuclear security – i.e. nuclear safety, radiation protection, prevention and fight against malicious acts, and also civil security actions in the event of an accident –, public health and sanitation or protection of nature and the environment), i.e. structure, equipment, system (programmed or not), material, component or software that is present in the Basic Nuclear Installation (INB) or that is under the responsibility of the nuclear operator and that implements a function required for the demonstration mentioned under the second paragraph of Article L. 593-7 of the Environmental Code (safety demonstration) or that ensures that this function is implemented.

As per articles 1.3 of the INB Order, a **PIA** is defined as an “Activity important for protecting the interests mentioned under Article L. 593-1 of the Environmental Code (public safety, health and sanitation, the protection of nature and of the environment), i.e. activity that falls under the technical or organizational provisions mentioned under the second paragraph of Article L. 593-7 of the Environmental Code or that is liable to affect them;”

As defined in Article 1.3 of the INB Order, **the Defined Requirements** are “requirement assigned to a protection important component so that it fulfils – with the expected characteristics – the function provided for in the demonstration mentioned in the second paragraph of Article L. 593-7 of the Environmental Code, or to a protection important activity so that it fulfils its objectives as regards this demonstration”. In other words, it means any requirement that has been assigned to a PIC or a PIA so that it may perform the function provided for in the safety demonstration.

[RQ-0143] As the Contract involves PIC or PIA, the Contractor shall comply with all the requirements expressed in “Provisions for implementation of the generic safety requirements by the external actors/interveners” [AD2]. The Contractor shall explain in its quality system or in a dedicated quality plan the measures taken to ensure compliance with these requirements. The Contractor shall ensure the propagation of these requirements to all its subcontractors and/or suppliers involved in PIC or PIA.

[RQ-0144] The Contractor shall put in place a technical control, as defined in Article 2.5.3 of the INB Order, for each PIA. Parties carrying out technical monitoring for a PIA are distinctly separate from the parties who perform the activities.

[RQ-0145] PIAs and their technical control shall be performed according to procedures (demonstration of compliance a priori) and be properly recorded (demonstration of compliance a posteriori).

[RQ-0146] The preliminary PIAs of this contract are listed below. It should be noted that these PIAs need to be updated when preparing MIP.

- Preparation of MIP
- Production & qualification of raw metallic materials
- Machining of sealing surfaces and relevant geometries
- Welding operation
- Assembly of optic disks and seals
- Packing and shipment

[RQ-0147] The performers of PIAs and of their technical control shall have necessary skill and qualification as per INB order 2.5.5.

SUPPLY

[RQ-0148] The Contractor shall ensure that these requirements are propagated to the Subcontractors and Suppliers as needed as per [AD3] and a demonstration of compliance shall be provided upon request of the CRO or SRO. The applicable “Defined Requirements” are provided in Appendix II.

[RQ-0149] The contractor shall be aware of “ITER Policy on Safety, Security and Environment Protection Management” [AD4] and make sure that it is propagated to the sub-contractors.

13 Contract Management

Requirement for [AD1] GM3S section 6 applies in full.

Appendix I – Manufacturing and inspection template for Manufacturing Database (MDB)

<https://user.iter.org/?uid=VGDUSJ&version=v2.3>

MANUFACTURING AND INSPECTION PLAN																			
Document number:			Revision number:																
ITER PA number:			ITER Contract Number:			Title of item:													
Name of DA/Supplier:			Subcontractor:																
Prepared by Subcontractor Name & Signature:			Approved by Manufacturer Name & Signature:				Approved by DA Name & Signature:				ITER Acceptance Name & Signature:				Control Points: HP: Hold point ATPP: Authorization to Proceed Point NP: Notification Point Standard Activities: W: Witness of Operation S1: 100% inspection, S2 Random inspection R: Report Required D - Recommend Report A: Approve S: Sign Off TC- Technical Control Required				
Position:Supplier Date:			Position: Date:				Position: TRO Date:				Position: Date:								
Operation id	Operations (Manufacture, inspections & Tests, etc.)	Expected Date	Operation type	PIA? (Y/N)	Subcontractor		Supplier		Inspection Body		IO		Others	Applicable document(s) version UID (V27V5_v1_2)	Applicable Documents or Drawings internal reference	Manufacturing drawing(s) version UID	Records (NCRs, reports, etc.)	Observation(s)	
					Name, signature and date	Action	Name, signature and date	Action	Name, Signature and Date	Action	Name, Signature and Date	Action	Name, Signature and Date						
1	Header 1																		
1.1	Material preparation							S - Sign Off		S - Sign Off				IDM UID	e.g. HX-FED-DOC-QD-301 Component list	IDM UID			
1.2	Material preparation							NP - Notification Point		NP - Notification Point				IDM UID		IDM UID			
1.3	Material preparation							R - Report Required		D - Recommend Report				IDM UID		IDM UID			
1.4	Material preparation							R - Report Required		D - Recommend Report				IDM UID		IDM UID			
2	Header 2																		
2.1	Material preparation							R - Report Required		D - Recommend Report				IDM UID	e.g. HX-FED-DOC-QD-301 Component list	IDM UID			
2.2	Material preparation							R - Report Required		D - Recommend Report				IDM UID		IDM UID			
2.3	Material preparation							R - Report Required		D - Recommend Report				IDM UID		IDM UID			
2.4	Material preparation							R - Report Required		D - Recommend Report				IDM UID		IDM UID			

Appendix II – Defined Requirements applicable to this contract

SRD ID	Defined Requirements	Propagated Requirements for the supply	Explanation
55NWs883	<i>SSCs of 55.NW in areas served by the detritiation systems or Tokamak Exhaust Processing System (TEPS) shall be free of Halogenated materials. Exceptions shall require a formal project approval (The procedure for formal project approval shall include approval of the Nuclear Safety and Tritium Plant Responsible Officers).</i>	[RQ-0008]	<i>Halogen-free is required</i>
55NWs958	55.NW PIC components shall satisfy the criteria identified in [ADc57 - ITER_D_347SF3 - - Safety Important Functions and Components Classification Criteria and Methodology] for classification and categorization of components.	[RQ-0146]~[RQ-0149]	In section 12, SIC-1 and PIC is declared. Propagated to the safety requirements related to PIC/PIA
55NWs979	<i>Modifications made to any part of the confinement barriers shall undergo re-testing to ensure that the integrated confinement leak rate has not been degraded.</i>	[RQ-0059]	
55NWs984	55.NW SSCs shall not contain inside themselves any radioactive or hazardous material but some 55.NW SIC components contribute to the overall IO strategy of providing two confinement systems for each	[RQ-0002][RQ-0003][RQ-0004] [RQ-0006] [RQ-0008]	

	principal inventory of radioactive or hazardous material.		
55NWs1006	For PIC components, assurance of the reliability performance of credited safety functions shall be provided using recognised analysis techniques.	[RQ-0087]~ [RQ-0100]	The FAT in Section 8 will assure the credited safety function
55NWs1001	Windows shall have a leak rate below the maximum defined in [ADi1], Table 3.1 - including during and after fires.	[RQ-0100]	He leak test is required in Section 8.3
55NWs1074	Vacuum windows (both primary and secondary) shall be pressure tested to demonstrate their ability to withstand 0.2 MPa (off-normal) internally, and proof tested to a pressure of 0.3 MPa.	[RQ-0091][RQ-0092][RQ-0098]	Pressure test is included in FAT
55NWs1076	Windows shall undergo a program of thermal cycling prior to assembly (see Ref. Doc [13]).	[RQ-0088]	Thermal cycling is included in FAT
55NWs1086	55.NW Windows shall be qualified to function under the magnetic conditions for which their service is required (during normal conditions or accident).	[RQ-0007]	Non-magnetic material is required.
55NWs1194	Prior to delivery to ITER site, the PIC SSCs of 55.NW shall be stored in clean and dry conditions, protected from normal hazards.	[RQ-0119]	
55NWs265	Data associated with 55.NW PIC functions shall be long term archived in a readable and safe way (protected from internal and external events and hazards without common mode failure) using the tools provided by the project for this purpose.	[RQ-0127][RQ-0128] [RQ-0141]	Documents are required to archive in IO system: IDM, SMDD and MDB.